

ABB INDUSTRIAL DRIVES

ACS880-31 drives

Quick installation guide



EN

USA

DA

DE

ES

FI

FR

IT

NL

PL

PT

RU

SV

TR

ZH

List of related manuals in English

Drive manuals and guides	Code (English)
<i>ACS880 primary control program firmware manual</i>	3AUA0000085967
<i>Quick start-up guide for ACS880 drives with primary control program</i>	3AUA0000098062
<i>ACS880-31 hardware manual</i>	3AXD50000045933
<i>ACS880-31 quick installation guide</i>	3AXD50000048171
<i>ACS-AP-x assistant control panels user's manual</i>	3AUA0000085685
Option manuals and guides	
<i>ACS880 drive module frames R1 to R9 for cabinet installation (options +P940 and +P944) supplement</i>	3AUA0000145446
<i>ACS880-11, ACS880-31, ACH580-31 and ACQ580-31 UK gland plate (+H358) installation guide</i>	3AXD50000110711
<i>FCAN-01 CANopen adapter module user's manual</i>	3AFE68615500
<i>FCNA-01 ControlNet adapter module user's manual</i>	3AUA0000141650
<i>FDNA-01 DeviceNet™ adapter module user's manual</i>	3AFE68573360
<i>FECA-01 EtherCAT adapter module user's manual</i>	3AUA0000068940
<i>FENA-01/-11/-21 Ethernet adapter module user's manual</i>	3AUA0000093568
<i>FEPL-02 Ethernet POWERLINK adapter module user's manual</i>	3AUA0000123527
<i>FPBA-01 PROFIBUS DP adapter module user's manual</i>	3AFE68573271
<i>FSCA-01 RS-485 adapter module user's manual</i>	3AUA0000109533
Tool and maintenance manuals and guides	
<i>Drive composer PC tool user's manual</i>	3AUA0000094606
<i>Converter module capacitor reforming instructions</i>	3BFE64059629
<i>NETA-21 remote monitoring tool user's manual</i>	3AUA0000096939
<i>NETA-21 remote monitoring tool installation and start-up guide</i>	3AUA0000096881

You can find manuals and other product documents in PDF format on the Internet.

See section [Document library on the Internet](#) on the inside of the back cover. For manuals not available in the Document library, contact your local ABB representative.

The code below opens an online listing of the manuals applicable to this product.



[ACS880-31 manuals](#)

EN – Quick installation guide

This guide briefly describes how to install the drive. For complete information on installation, see *ACS880-31 drives hardware manual* (3AXD50000045933 [English]). For start-up instructions, see *ACS880 drives with primary control program quick start-up guide* (3AUA0000098062 [English]).

To read a manual, go to www.abb.com/drives/documents and search for the document number.

EN

Obey the safety instructions



WARNING! Obey these instructions. If you ignore them, injury or death, or damage to the equipment can occur:

- Only qualified electrical professionals are allowed to install and maintain the drive.
 - Never work on the drive, motor cable or motor when main power is applied. If the drive is already connected to the input power, wait for 5 minutes after disconnecting the input power.
 - Never work on the control cables when power is applied to the drive or to the external control circuits.
 - Do not connect the drive to a voltage higher than what is marked on the type designation label.
 - Always ground the drive, the motor and adjoining equipment to the protective earth (PE) bus of the power supply.
 - **Frames R6 and R8:** The drive module is heavy and its center of gravity is high. Use a lifting device for lifting. Do not tilt the drive. Manual lifting, or overturning due to the tilting, can cause physical injury. Make sure that the wall and the fixing devices can carry the weight.
 - Make sure that debris from drilling, cutting and grinding does not enter the drive.
 - Make sure that the floor below the drive and the wall where the drive is installed are non-flammable.
-

Check if capacitors need to be reformed

If the drive has not been powered (either in storage or unused) for over three years, you must reform the capacitors.

You can determine the manufacturing date from the serial number, which you find on the type designation label attached to the drive. The serial number is of format MYYWWRXXXX. YY and WW tell the manufacturing year and week as follows:

YY: 17, 18, 19, ... for 2017, 2018, 2019, ...

WW: 01, 02, 03, ... for week 1, week 2, week 3, ...

For information on reforming the capacitors, see *Converter module capacitor reforming instructions* (3BFE64059629 [English]), available on the Internet at www.abb.com/drives/documents.

Data

IEC ratings

EN

ACS880-31	Cable (mm ²)	aR fuse	Losses (W)
3-phase $U_N = 400$ V (380...415 V)			
09A4-3	3×1.5	170M1561	226
12A6-3	3×1.5	170M1561	329
017A-3	3×6	170M1563	395
025A-3	3×6	170M1563	579
032A-3	3×10	170M1565	625
038A-3	3×10	170M1565	751
045A-3	3×16	170M1566	912
061A-3	3×25	170M1567	1088
072A-3	3×35	170M1568	1502
087A-3	3×50	170M1569	1904
105A-3	3×50	170M3817	1877
145A-3	3×95	170M3817	2963
169A-3	3×120	170M5809	3168
206A-3	3×150	170M5810	3990
3-phase $U_N = 500$ V (380...500 V)			
07A6-5	3×1.5	170M1561	219
11A0-5	3×1.5	170M1561	278
014A-5	3×6	170M1563	321
021A-5	3×6	170M1563	473
027A-5	3×10	170M1565	625
034A-5	3×10	170M1565	711
040A-5	3×16	170M1566	807
052A-5	3×25	170M1567	960
065A-5	3×35	170M1568	1223
077A-5	3×35	170M1569	1560
101A-5	3×50	170M3816	1995
124A-5	3×95	170M3817	2800
156A-5	3×120	170M5808	3168
180A-5	3×150	170M5810	3872

3AXD00000588487

Select the power cables

See [Data](#) on page 4.

Ensure cooling

See [Data](#) on page 4. No condensation or frost is allowed. The allowed operating temperature range of the drive without derating is -15 to +40 °C.

Protect the drive and input power cable

See [Data](#) on page 4.

A – Install the drive on the wall

See figure [A](#) on page 137.

B – Remove the cover

Remove the cover/s. See figures [B \(R3\)](#) and [B \(R6, R8\)...](#) on page 137.

C – Check the compatibility with IT (ungrounded) and corner-grounded delta systems

See figure [C](#) on page 137.



WARNING! If the drive will be connected on an IT (ungrounded or high-resistance grounded) system or on a corner-grounded delta system, disconnect the EMC filter (option +E202) and ground-to-phase varistor. See the drive hardware manual.

D – Check the insulation of the power cables and the motor

Connect the motor cable at the motor end. For minimum radio frequency interference, ground the motor cable shield 360 degrees at the cable entry of the motor terminal box. See figure [D](#) on page 137.

Check the insulation of motor and motor cable. See figure [D](#) on page 137. **Note:** Moisture inside the motor casing will reduce the insulation resistance. If moisture is suspected, dry the motor and repeat the measurement.

Check the insulation of the input cable before connecting it to the drive. Obey the local regulations.

E – Attach the warning stickers in local languages

See figure [E](#) on page 138.

F – Connect the power cables

Use symmetrical shielded cable for motor cabling. If the cable shield is the sole PE conductor, make sure that it has sufficient conductivity for the PE.

Note for frame R3: Make sure that you have an additional PE conductor in the input power cabling. See the hardware manual for more information.

Procedure:

1. Frame R6 and R8: Remove the shroud on the power cable terminals. See figure *F (R6, R8)*... on page 138. Frame R8: For easier installation, remove the side plates.
2. Remove the rubber grommets from the bottom plate for the cables to be connected. See figure *...F...* on page 138.
3. Cut an adequate hole into the rubber grommets. Slide the grommets onto the cables.

EN

4. Prepare the ends of the cables. See figure *...F...* on page 138.

The bare shield will be grounded 360 degrees. Mark the pigtail made from the shield as a PE conductor with yellow-and-green color.

Two alternative symmetrical three-conductor cable types are shown, and one four-conductor cable type. The four-conductor cable is only allowed for the input power cabling.

If you use aluminum cables, put grease to the peeled aluminum cable before connecting it to the drive.

5. Put the cables through the holes of the cable entry plate and attach the grommets to the holes.
6. Connect the cables (use the torques defined in the figure). See figures *...F...* on page 138 and 139:
 - Ground the shield 360 degrees by tightening the clamp of the power cable grounding shelf onto the stripped part of the cable.
 - Connect the twisted shield of the cable to the grounding terminal.
 - Use a separate grounding PE cable (6a) or a cable with a separate PE conductor (6b) if the conductivity of the shield does not meet the requirements for the PE conductor. If the protective PE conductor is smaller than 10 mm², you must use a second earthing conductor. See the hardware manual for more information.
 - Frame R3: Connect the additional PE conductor of the input power cabling.
 - Connect the phase conductors of the motor cable to the T1/U, T2/V and T3/W terminals and the phase conductors of the input cable to the L1, L2 and L3 terminals.

7. Frame R6 types bigger than -040A-x: Cut tabs in the shroud for the installed cables. Frame R8: Install the side plates if removed. Knock out holes in the shroud for the input cables. See figure [...F \(R6, R8\)...](#) on page 139.
8. Frames R6 and R8: Install the shroud on the power cable terminals. See figure [...F \(R6, R8\)...](#) on page 139.
9. Secure the cables outside the drive mechanically.

G – Connect the control cables

Procedure:

1. Remove the front cover(s) if not already removed.
2. Frame R3: Lift the control panel holder up. See figure [G \(R3\)...](#) on page 139.
3. Cut an adequate hole into the rubber grommet and slide the grommet onto the cable. Slide the cable through a hole in the bottom plate and attach the grommet to the hole.
4. Route the cables. Frame R3: See figure [...G \(R3\)...](#) on page 139. Frame R6: See figure [...G \(R6\)...](#) on page 139. Frame R8: See figure [...G \(R8\)...](#) on page 140.
5. Ground the outer shield of the cable 360 degrees under the grounding clamp. Keep the cable unstripped as close to the terminals of the control board as possible.
6. Secure the cables inside the drive mechanically.
7. Frame R3: Leave the pair cable shields and grounding wires unconnected at the drive end, and ground them at the other cable end. Cut any unconnected wires at the drive end. Frame R6 and R8: Ground the pair-cable shields and grounding wire under the clamp below the control unit.
8. Connect the conductors to the appropriate terminals of the control unit. See [Default IO connection diagram](#) on page 8.
9. Wire the optional modules if included in the delivery. See the option module user's manual or installation guide.
10. Secure the cables outside the drive mechanically.

Note:

- Leave the other ends of the control cable shields unconnected.
- Keep any signal wire pairs twisted as close to the terminals as possible.

H – Reinstall cover(s)

See figures [H \(R3, R6, R8\)...](#) on page 140.

Default IO connection diagram

Wire sizes:
0.5 ... 2.5 mm²
(24... 14 AWG)

Tightening
torques: 0.5 N·m
(0.4 lbf·ft) for
both stranded
and solid wiring.

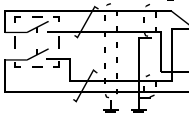
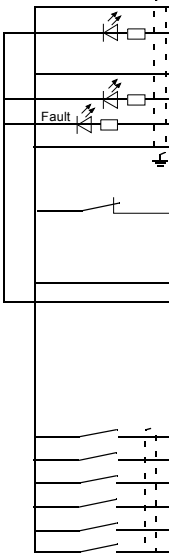
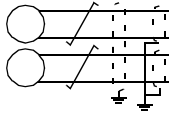
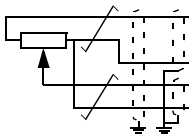

XPOW External power input		
1	+24VI	24 V DC, 2 A
2	GND	

XAI Reference voltage and analog inputs		
1	+VREF	10 V DC, R_i 1...10 kohm
2	-VREF	-10 V DC, R_i 1...10 kohm
3	AGND	Ground
4	AI1+	Speed reference 0(2)...10 V, $R_{in} > 200$ kohm
5	AI1-	
6	AI2+	By default not in use. 0(4)...20 mA, $R_{in} = 100$ ohm
7	AI2-	
J1	J1	AI1 current/voltage selection jumper
J2	J2	AI2 current/voltage selection jumper

XAO Analog outputs		
1	AO1	Motor speed rpm 0...20 mA, $R_L < 500$ ohm
2	AGND	
3	AO2	Motor current 0...20 mA, $R_L < 500$ ohm
4	AGND	

XD2D Drive-to-drive link		
1	B	Drive-to-drive link
2	A	
3	BGND	
J3	J3	Drive-to-drive link termination switch

XRO1, XRO2, XRO3 Relay outputs		
11	NC	Ready 250 V AC / 30 V DC 2 A
12	COM	
13	NO	
21	NC	Running 250 V AC / 30 V DC 2 A
22	COM	
23	NO	
31	NC	Faulted(-1) 250 V AC / 30 V DC 2 A
32	COM	
33	NO	

XD24 Digital interlock		
1	DIIL	Run enable
2	+24VD	+24 V DC 200 mA
3	DICOM	Digital input ground
4	+24VD	+24 V DC 200 mA
5	DIOGND	Digital input/output ground
J6	Ground selection switch	

XDIO Digital input/outputs		
1	DIO1	Output: Ready
2	DIO2	Output: Running

XDI Digital inputs		
1	DI1	Stop (0) / Start (1)
2	DI2	Forward (0) / Reverse (1)
3	DI3	Reset
4	DI4	Acceleration & deceleration select
5	DI5	Constant speed 1 (1 = On)
6	DI6	By default not in use.

XSTO Safe torque off		
1	OUT1	Safe torque off. Both circuits must be closed for the drive to start.
2	SGND	
3	IN1	
4	IN2	

X12	Safety functions module connection	
X13	Control panel connection	
X205	Memory unit connection	

Declaration of Conformity (EU)

Power and productivity
for a better world™



EU Declaration of Conformity

Machinery Directive 2006/42/EC

We

Manufacturer: ABB Oy
Address: Hiomotie 13, 00380 Helsinki, Finland.
Phone: +358 10 22 11

declare under our sole responsibility that the following products:

Frequency converters

ACS880-01

ACS880-04/-04F

ACS880-M04

ACS880-11/-31/-14/-34

with regard to the built-in safety function:

Safe torque off;

and with regard to the following optional safety functions with FSO-12 module (option code +Q973, encoderless):

Safe stop 1; Safe stop emergency; Safely-limited speed; Safe maximum speed; Safe brake control; Prevention of Unexpected Start-up;

and with regard to the following optional safety functions (option codes +Q972 and +L521, encoder supported):

Safe stop 1; Safe stop emergency; Safely-limited speed; Safe maximum speed; Safe brake control; Safe speed monitor; Safe direction; Prevention of Unexpected Start-up;

and with regard to the following optional safety function with FPTC-01 thermistor protection module (option code +L536):

Safe Motor Temperature;

are in conformity with all the relevant safety component requirements of EU Machinery Directive 2006/42/EC, when the listed safety functions are used for safety component functionality.

Power and productivity
for a better world™



EU Declaration of Conformity

Machinery Directive 2006/42/EC

The following harmonized standards have been applied:

EN 61800-5-2:2007	<i>Adjustable speed electrical power drive systems – Part 5-2: Safety requirements - Functional</i>
EN 62061:2005 + AC:2010 + A1:2013 + A2:2015	<i>Safety of machinery – Functional safety of safety-related electrical, electronic and programmable electronic control systems</i>
EN ISO 13849-1:2015	<i>Safety of machinery – Safety-related parts of control systems. Part 1: General requirements</i>
EN ISO 13849-2:2012	<i>Safety of machinery – Safety-related parts of the control systems. Part 2: Validation</i>
EN 60204-1: 2006 + A1:2009 + AC:2010	<i>Safety of machinery – Electrical equipment of machines – Part 1: General requirements</i>

The following other standards have been applied:

IEC 61508:2010	<i>Functional safety of electrical / electronic / programmable electronic safety-related systems</i>
IEC 61800-5-2:2016	<i>Adjustable speed electrical power drive systems – Part 5-2: Safety requirements - Functional</i>

The products referred in this Declaration of conformity fulfil the relevant provisions of other European Union Directives which are notified in Single EU Declaration of conformity 3AXD10000497831.

Person authorized to compile the technical file:

Name and address: Juha Martinmaa, Hiomotie 13, 00380 Helsinki, Finland.

Helsinki, 15 Sep 2017

Manufacturer representative:

Vesa Kandell
Vice President, ABB Oy

EN – USA quick installation guide

This guide briefly describes how to install the drive. For complete information on installation, see *ACS880-31 drives hardware manual* (3AXD50000045933 [English]). For start-up instructions, see *ACS880 drives with primary control program quick start-up guide* (3AUA0000098062 [English]).

To read a manual, go to abb.com/drives/documents and search for the document number.

Obey the safety instructions



WARNING! Obey these instructions. If you ignore them, injury or death, or damage to the equipment can occur:

- Only qualified electrical professionals are allowed to install and maintain the drive.
 - Never work on the drive, motor cable or motor when main power is applied. If the drive is already connected to the input power, wait for 5 minutes after disconnecting the input power.
 - Never work on the control cables when power is applied to the drive or to the external control circuits.
 - Do not connect the drive to a voltage higher than what is marked on the type designation label.
 - Always ground the drive, the motor and adjoining equipment to the protective earth (PE) bus of the power supply.
 - **Frames R6 and R8:** The drive module is heavy and its center of gravity is high. Use a lifting device for lifting. Do not tilt the drive. Manual lifting, or overturning due to the tilting, can cause physical injury. Make sure that the wall and the fixing devices can carry the weight.
 - Make sure that debris from drilling, cutting and grinding does not enter the drive.
 - Make sure that the floor below the drive and the wall where the drive is installed are non-flammable.
-

Check if capacitors need to be reformed

If the drive has not been powered (either in storage or unused) for over three years, you must reform the capacitors.

You can determine the manufacturing date from the serial number, which you find on the type designation label attached to the drive. The serial number is of format MYYWWRXXXX. YY and WW tell the manufacturing year and week as follows:

YY: 17, 18, 19, ... for 2017, 2018, 2019, ...

WW: 01, 02, 03, ... for week 1, week 2, week 3, ...

For information on reforming the capacitors, see *Converter module capacitor reforming instructions* (3BFE64059629 [English]), available on the Internet at abb.com/drives/documents.

Data

■ UL (NEC) ratings

ACS880-31	Cu cable (AWG/kcmil)	UL fuse	Losses (W)
3-phase $U_N = 480$ V (440, 460, 480 V)			
07A-5	14	JJS-15	219
11A0-5	14	JJS-20	278
014A-5	10	JJS-25	321
021A-5	10	JJS-35	473
027A-5	8	JJS-40	625
034A-5	8	JJS-50	711
040A-5	6	JJS-60	807
052A-5	4	JJS-80	960
065A-5	2	JJS-90	1223
077A-5	2	JJS-110	1560
101A-5	1	JJS-150	1995
124A-5	2/0	JJS-200	2800
156A-5	3/0	JJS-225	3168
180A-5	250MCM	JJS-300	3872

3AXD00000568487

Select the power cables

See the [Data](#) table on page 12.

Ensure cooling

See the [Data](#) table on page 12. No condensation or frost is allowed. The allowed operating temperature range of the drive without derating is -15 to +40 °C.

Protect the drive and input power cable

Check on the fuse time-current curve to ensure that the operating time of the fuse is below 0.1 seconds. Obey the local regulations.

A – Install the drive on the wall

See figure [A](#) on page 141.

Frames R6 and R8 of UL Type 12 (option +B056): Install an additional hood on top of the drive before you tighten the upper fastening screws. Place the vertical edge of the hood in between the wall and the drive back plate. Then tighten the screws to fasten the hood and drive on its place. See figure [A \(R6, R8\)](#) on page 141.

B – Remove the cover

Remove the cover(s). See figures [B \(R3\)](#) and [B \(R6, R8\)](#)... on page [141](#).

C – Check the compatibility with IT (ungrounded) and corner-grounded delta systems

See figure [C](#) on page [141](#).



WARNING! If the drive will be connected on an IT (ungrounded or high-resistance grounded) system or on a corner-grounded delta system, disconnect the EMC filter (option +E202) and ground-to-phase varistor. See the drive hardware manual.

USA

D – Check the insulation of the power cables and the motor

Check the insulation of motor and motor cable. See figure [D](#) on page [142](#). **Note:** Moisture inside the motor casing will reduce the insulation resistance. If moisture is suspected, dry the motor and repeat the measurement.

Check the insulation of the input cable before connecting it to the drive. Obey the local regulations.

E – Attach the warning stickers in local languages

See figure [E](#) on page [142](#).

F – Connect the power cables

Procedure:

1. Frame R6 and R8: Remove the shroud on the power cable terminals. See figure [F \(R6, R8\)](#)... on page [142](#). Frame R8: For easier installation, remove the side plates.
 2. Remove the rubber grommets from the bottom plate for the cable conduits to be installed. See figure [...F...](#) on page [142](#).
 3. Attach the cable conduits to the bottom plate holes. See figure [...F...](#) on page [142](#).
 4. Remove the cable shelves (4a). Reinstall the four screws to avoid moisture exchange through the empty holes! (4b). See figure [...F \(R6, R8\)](#)... on page [142](#).
 5. Strip the cable ends. (Note the extra length of the grounding conductors.) Slide the cables through the connectors. See figure [...F...](#) on page [142](#).
-

6. Connect the grounding conductors to the grounding terminals. Connect the conductors of the input and motor cables. Tighten the screws. See figures [...F \(R3\)...](#), [...F \(R6\)...](#) and [...F \(R8\).....](#) on page [142](#).

Connect the phase conductors of the motor cable to the T1/U, T2/V and T3/W terminals and the phase conductors of the input cable to the L1, L2 and L3 terminals.

If the protective PE conductor is smaller than 10 mm², you must use a second earthing conductor (6a). See the hardware manual for more information.

7. Frame R6 types bigger than -040A-x: Cut tabs in the shroud for the installed cables. Frame R8: Install the side plates if removed. Knock out holes in the shroud for the input cables. See figure [...F \(R6, R8\)...](#) on page [143](#).

8. Frames R6 and R8:: Install the shroud on the power cable terminals.

USA

G – Connect the control cables

Procedure:

1. Remove the front cover(s) if not already removed.
2. Frame R3: Lift the control panel holder up. See figure [G \(R3\)...](#) on page [143](#).
3. Remove the rubber grommets from the bottom plate for the cable conduits to be installed.
4. Attach the cable conduits to the bottom plate holes.
5. Strip the cable ends and cut to suitable length (note the extra length of the grounding conductors).
6. Route the cables. Frame R3: See figure [...G \(R3\)...](#) on page [143](#). Frame R6: See figure [...G \(R6\)...](#) on page [144](#). Frame R8: See figure [...G \(R8\)...](#) on page [144](#).
7. Secure the cables inside the drive with cable ties.
8. Frame R3: Leave the pair cable shields and grounding wires unconnected at the drive end, and ground them at the other cable end. Cut any unconnected wires at the drive end. Frame R6 and R8: Ground the pair-cable shields and grounding wire under the clamp below the control unit.
9. Connect the conductors to the appropriate terminals of the control unit. See [Default IO connection diagram](#) on page [16](#).
10. Wire the optional modules if included in the delivery. See the option module user's manual or installation guide.

Note:

- Leave the other ends of the control cable shields unconnected.
 - Keep any signal wire pairs twisted as close to the terminals as possible.
-

H – Reinstall cover(s)

See figures [H \(R3, R6, R8\)](#)... on page [145](#).

Default IO connection diagram

Wire sizes:
0.5 ... 2.5 mm²
(24... 14 AWG)

Tightening
torques: 0.5 N·m
(0.4 lbf·ft) for
both stranded
and solid wiring.

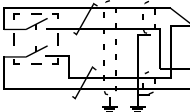
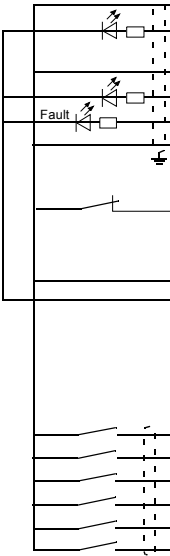
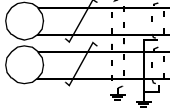
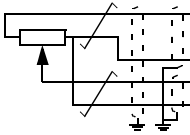

XPOW External power input		
1	+24VI	24 V DC, 2 A
2	GND	

XAI Reference voltage and analog inputs		
1	+VREF	10 V DC, R_i 1...10 kohm
2	-VREF	-10 V DC, R_i 1...10 kohm
3	AGND	Ground
4	AI1+	Speed reference 0(2)...10 V, $R_{in} > 200$ kohm
5	AI1-	
6	AI2+	By default not in use. 0(4)...20 mA, $R_{in} = 100$ ohm
7	AI2-	
J1	J1	AI1 current/voltage selection jumper
J2	J2	AI2 current/voltage selection jumper

XAO Analog outputs		
1	AO1	Motor speed rpm 0...20 mA, $R_L < 500$ ohm
2	AGND	
3	AO2	Motor current 0...20 mA, $R_L < 500$ ohm
4	AGND	

XD2D Drive-to-drive link		
1	B	Drive-to-drive link
2	A	
3	BGND	
J3	J3	Drive-to-drive link termination switch

XRO1, XRO2, XRO3 Relay outputs		
11	NC	Ready 250 V AC / 30 V DC 2 A
12	COM	
13	NO	
21	NC	Running 250 V AC / 30 V DC 2 A
22	COM	
23	NO	
31	NC	Faulted(-1) 250 V AC / 30 V DC 2 A
32	COM	
33	NO	

XD24 Digital interlock		
1	DIIL	Run enable
2	+24VD	+24 V DC 200 mA
3	DICOM	Digital input ground
4	+24VD	+24 V DC 200 mA
5	DIOGND	Digital input/output ground
J6	Ground selection switch	

XDIO Digital input/outputs		
1	DIO1	Output: Ready
2	DIO2	Output: Running

XDI Digital inputs		
1	DI1	Stop (0) / Start (1)
2	DI2	Forward (0) / Reverse (1)
3	DI3	Reset
4	DI4	Acceleration & deceleration select
5	DI5	Constant speed 1 (1 = On)
6	DI6	By default not in use.

XSTO Safe torque off		
1	OUT1	Safe torque off. Both circuits must be closed for the drive to start.
2	SGND	
3	IN1	
4	IN2	

X12	Safety functions module connection	
X13	Control panel connection	
X205	Memory unit connection	

USA

UL checklist



WARNING! Operation of this drive requires detailed installation and operation instructions provided in the hardware and software manuals. The manuals are provided in electric format in the drive package or on the Internet. Retain the manuals with the drive at all times. Hard copies of the manuals can be ordered through the manufacturer.

- Make sure that the drive type designation label includes the cULus Listed marking.
- **CAUTION - Risk of electric shock.** After disconnecting the input power, always wait for 5 minutes to let the intermediate circuit capacitors discharge before you start working on the drive, motor or motor cable.
- The drive is to be used in a heated, indoor controlled environment. The drive must be installed in clean air according to enclosure classification. Cooling air must be clean, free from corrosive materials and electrically conductive dust. See the hardware manual.
- The maximum surrounding air temperature is +55 °C (131 °F) at rated current. The current is derated for 40 to 55 °C (104 to 131 °F).
- The drive is suitable for use in a circuit capable of delivering not more than 100,000 rms symmetrical amperes, 480 V maximum when protected by the UL fuses on page 12. The ampere rating is based on tests done according to the appropriate UL standard.
- The cables located within the motor circuit must be rated for at least 75 °C (167 °F) in UL-compliant installations.
- The input cable must be protected with fuses. The fuses must provide branch circuit protection in accordance with the national regulations (National Electrical Code (NEC) or Canadian Electrical Code). Obey also any other applicable local or provincial codes.
- **Note:** Circuit breakers must not be used without fuses in the USA. Contact your local representative for suitable circuit breakers.



WARNING! The opening of the branch-circuit protective device may be an indication that a fault current has been interrupted. To reduce the risk of fire or electric shock, current-carrying parts and other components of the device should be examined and replaced if damaged.

- The drive provides motor overload protection. For adjustments, see the firmware manual.
- For the drive overvoltage category and pollution degree, see the hardware manual.

USA

DA – Hurtig installationsvejledning

Denne vejledning giver en kortfattet beskrivelse af, hvordan du installerer frekvensomformerer. Du finder fuldstændige oplysninger om installationen i *ACS880-31 drives hardware manual* (3AXD50000045933 (på engelsk)). Se opstartsinstruktionerne i *ACS880 drives with primary control program quick start-up guide* (3AUA0000098062 (på engelsk)).

Du kan læse en manual ved at gå til www.abb.com/drives/documents og søge efter dokumentnummeret.

Overhold sikkerhedsinstruktionerne



ADVARSEL! Følg disse instruktioner. Hvis de ignoreres, kan det resultere i personskader, dødsfald eller skade på udstyret:

- Kun autoriserede elinstallatører må udføre installation og vedligeholdelse af frekvensomformerer.
 - Undlad at arbejde med frekvensomformerer, motorkablet eller motoren, når tilslutning til nettet er foretaget. Hvis frekvensomformerer allerede er tilsluttet netforsyningen, skal du vente 5 minutter efter frakobling af netspændingen.
 - Du må aldrig arbejde med signalkablerne, når netspændingen er tilsluttet frekvensomformerer eller de eksterne styrekredse.
 - Frekvensomformerer må ikke tilsluttes til en spænding, der er højere end den, der er angivet på typebetegnelsesmærkaten.
 - Frekvensomformerer, motoren og tilstødende udstyr skal altid jordes med strømforsyningens beskyttelsesjordbus (PE).
 - **Modul R6 og R8:** Frekvensomformermodul er tungt og har et højt tyngdepunkt. Brug en løfteanordning til at løfte med. Frekvensomformerer må ikke vippe. Manuelle løft eller væltning som følge af tipning af frekvensomformerer kan forårsage fysiske skader. Sørg for, at væggen og fastgørelsesanordningerne kan understøtte vægten.
 - Undgå, at der trænger smuds fra borer, skæring eller slibning ind i frekvensomformerer under installation.
 - Sørg for, at gulvet under frekvensomformerer og den væg, hvor frekvensomformerer installeres, ikke er brændbare.
-

Kontrollér, om det er nødvendigt at reformere kondensatorerne

Hvis frekvensomformerer ikke har været tilsluttet spænding (opbevaret eller ikke anvendt) i over tre år, skal du reformere kondensatorerne.

Du kan bestemme produktionsdatoen ud fra serienummeret, som du finder på typebetegnelsesmærket på frekvensomformereren. Serienummeret har formatet MYYWWRXXXX. YY og WW angiver produktionsåret og ugen på følgende måde:

YY: 17, 18, 19, ... for 2017, 2018, 2019, ...

WW: 01, 02, 03, ... for uge 1, uge 2, uge 3, ...

Oplysninger om reformering af kondensatorer findes i *Converter module capacitor reforming instructions* (3BFE64059629 (på engelsk)), som findes på internettet på www.abb.com/drives/documents.

Data

IEC-klassificeringer

DA

ACS880-31	Kabel (mm ²)	aR-sikring	Tab (W)
3-faset $U_N = 400$ V (380...415 V)			
09A4-3	3×1.5	170M1561	226
12A6-3	3×1.5	170M1561	329
017A-3	3×6	170M1563	395
025A-3	3×6	170M1563	579
032A-3	3×10	170M1565	625
038A-3	3×10	170M1565	751
045A-3	3×16	170M1566	912
061A-3	3×25	170M1567	1088
072A-3	3×35	170M1568	1502
087A-3	3×50	170M1569	1904
105A-3	3×50	170M3817	1877
145A-3	3×95	170M3817	2963
169A-3	3×120	170M5809	3168
206A-3	3×150	170M5810	3990
3-faset $U_N = 500$ V (380...500 V)			
07A6-5	3×1.5	170M1561	219
11A0-5	3×1.5	170M1561	278
014A-5	3×6	170M1563	321
021A-5	3×6	170M1563	473
027A-5	3×10	170M1565	625
034A-5	3×10	170M1565	711
040A-5	3×16	170M1566	807
052A-5	3×25	170M1567	960
065A-5	3×35	170M1568	1223
077A-5	3×35	170M1569	1560
101A-5	3×50	170M3816	1995
124A-5	3×95	170M3817	2800
156A-5	3×120	170M5808	3168
180A-5	3×150	170M5810	3872

3AXD00000588487

Vælg effektkabler

Se [Data](#) på side [20](#).

Sørg for køling

Se [Data](#) på side [20](#). Kondensation eller frost er ikke tilladt. Frekvensomformerens tilladte driftstemperaturområde uden reduktion er -15 til +40 °C.

Beskyt frekvensomformereren og netkablet

Se [Data](#) på side [20](#).

A – Installer frekvensomformereren på væggen

Se figur [A](#) på side [137](#).

DA

B – Fjern dækslet

Fjern dækslet/dækslerne. Se figurerne [B \(R3\)](#) og [B \(R6, R8\)](#)... på side [137](#).

C – Kontrollér kompatibiliteten med IT-net (ujordede) og hjørnejordede delsystemer

Se figur [C](#) på side [137](#).



ADVARSEL! Hvis frekvensomformereren tilsluttes på et It-net (ujordede eller højmodstandsjordede) eller på et hjørnejordet delsystem, skal du frakoble EMC-filtret (ekstraudstyr +E202) og jord-til-fase-varistor. Se frekvensomformerens hardwaremanual.

D – Kontrollér isoleringen på effektkablerne og motoren.

Tilslut motorkablet i motorenden. For at opnå mindst mulig radiofrekvensinterferens jordes motorkabelskærmen 360 grader ved kabelindgangen i motorklemkassen. Se figur [D](#) på side [137](#).

Kontrollér isoleringen af motor og motorkabel. Se figur [D](#) på side [137](#). **Bemærk!** Fugt inden i motorhuset reducerer isolationsmodstanden. Hvis der er mistanke om fugt, skal motoren tørres, og målingen gentages.

Kontrollér isoleringen af indgangskablet, inden det tilsluttes frekvensomformereren. Overhold de lokale bestemmelser.

E – Fastgør advarselmærkaterne på de lokale sprog

Se figur [E](#) på side [138](#).

F – Tilslut effektkablerne

Anvend et skærmet symmetrisk kabel til motorkabling. Hvis kabelskærmen er den eneste PE-leder, skal du sørge for, at den har tilstrækkelig ledeevne til PE'en.

Note til modul R3: Du skal sikre dig, at du har en ekstra PE-leder i effektkablet til indgangen. Se hardwaremanualen for at få flere oplysninger.

Procedure:

1. Modul R6 og R8: Fjern afdækningen på effektkabelterminalerne. Se figur *F (R6, R8)*... på side 138. Modul R8: Fjern sidepladerne for nemmere at kunne installere.
2. Fjern gummimufferne fra bundpladen, så kablerne kan tilsluttes. Se figur *...F...* på side 138.
3. Skær et tilstrækkeligt stort hul i gummimufferne. Træk mufferne over på kablerne.
4. Forbered kabelenderne. Se figur *...F...* på side 138.
Afskærmningen jordes 360 grader. Markér det øje, der dannes af skærmen, som en PE-leder med gult og grønt.
Der er vist to alternative symmetriske trelederkabletyper samt en firlederkabletype. Firlederkablet må kun bruges ved effektkablet til indgangen.
Hvis du bruger aluminiumskabler, skal du smøre fedt på det skrællede aluminiumskabel, før du slutter det til frekvensomformerens.
5. Før kablerne gennem hullerne på indgangspladen, og sæt mufferne fast i hullerne.
6. Tilslut kablerne (brug de momenter, der er defineret i figuren). Se figurerne *...F...* på side 138 og 139:
 - Jord skærmene 360 grader ved at spænde klemmen på netkablets jordingsplint fast på den afisolerede del af kablet.
 - Forbind den snoede del af kabelskærmen med jordterminalen.
 - Brug et separat jordet PE-kabel (6a) eller et kabel med separat PE-leder (6b), hvis skærmens ledeevne ikke opfylder kravene til PE-lederen. Hvis PE-lederen til beskyttelse er mindre end 10 mm^2 , skal du bruge en ekstra jordleder. Se hardwaremanualen for at få flere oplysninger.
 - Modul R3: Tilslut den ekstra PE-leder for effektkablet til indgangen.
 - Forbind motorkablets faseledere med terminalerne T1/U, T2/V og T3/W samt indgangskablets faseledere med terminalerne L1, L2 og L3.
7. Modul R6-typer større end -040A-x: Skær tapper i afskærmningen til de installerede kabler. Modul R8: Montér sidepladerne, hvis de har været fjernet. Lav huller i afskærmningen til indgangskablerne. Se figur *...F (R6, R8)*... på side 139.
8. Modul R6 og R8: Installér afdækningen på effektkabelterminalerne. Se figur *...F (R6, R8)*... på side 139.

9. Fastgør kablerne mekanisk udvendigt på frekvensomformereren.

G – Tilslutning af styrekablerne

Procedure:

1. Fjern frontdækslet/-dækslerne, hvis det ikke allerede er gjort.
2. Modul R3: Løft betjeningspanelets holder op. Se figur [G \(R3\)](#)... på side [139](#).
3. Klip et passende hul i gummimuffen, og skub muffen på kablet. Før kablet gennem et hul i bundpladen, og sæt muffen fast i hullet.
4. Træk kablerne. Modul R3: Se figur [...G \(R3\)](#)... på side [139](#). Modul R6: Se figur [...G \(R6\)](#)... på side [139](#). Modul R8: Se figur [...G \(R8\)](#)... på side [140](#).
5. Jord den udvendige skærm på kablet 360 grader under jordingsklemmen. Kablet skal være isoleret så tæt på terminalerne på styrekortet som muligt.
6. Fastgør kablerne mekanisk indvendigt på frekvensomformereren.
7. Modul R3: Undlad at tilslutte skærmene på de parsnoede kabler og jordkabler ved frekvensomformerens ende, og jord dem i den anden kabelende. Klip alle ikke-tilsluttede kabler ved frekvensomformerens ende. Modul R6 og R8: Jord skærmene på de parsnoede kabler og alle jordkabler under klemmen under styreenheden.
8. Forbind kablets ledere til de korrekte klemmer på styreenheden. Se [Diagram over I/O-standardtilslutninger](#) på side [24](#).
9. Forbind de valgfrie moduler, hvis de indgår i leverancen. Se ekstramodulets brugermanual eller installationsvejledning.
10. Fastgør kablerne mekanisk udvendigt på frekvensomformereren.

Bemærk!

- Lad de andre ender af styrekabelskærmen være uforbundet.
- Lad parvise signalkabler være snoet så tæt på terminalerne som muligt.

H – Geninstaller dæksel eller dæksler.

Se figurene [H \(R3, R6, R8\)](#)... på side [140](#).

■ Diagram over I/O-standardtilslutninger

Ledningsstørrelse:
0,5 ... 2,5 mm²
(24... 14 AWG)
Fastsævningsmomenter:
0,5 N·m
(0,4 lbf·ft) til
både trådedere
og stive ledere.

XPOW Ekstern strømforsyning	
1	+24VI
2	GND
24 V DC, 2 A	
XAI Referencespænding og analoge indgange	
1	+VREF
2	-VREF
3	AGND
4	AI1+
5	AI1-
6	AI2+
7	AI2-
J1	J1
J2	J2
10 V DC, R _i 1...10 kohm	
-10 V DC, R _i 1...10 kohm	
Jord	
Hastighedsreference 0(2)...10 V, R_{in} > 200 kohm	
Som standardindstilling ubenyttet.	
0(4)...20 mA, R _{in} = 100 ohm	
AI1-jumper til valg af strøm/spænding	
AI2-jumper til valg af strøm/spænding	
XAO Analoge udgange	
1	AO1
2	AGND
3	AO2
4	AGND
Motorhastighed 0/min 0...20 mA, R_L < 500 ohm	
Motorstrøm 0...20 mA, R_L < 500 ohm	
XD2D Drev-til-drev-forbindelse	
1	B
2	A
3	BGND
J3	J3
Drev-til-drev-forbindelse	
Afbryder til drev-til-drev-forbindelse	
XRO1, XRO2, XRO3 Relæudgange	
11	NC
12	COM
13	NEJ
21	NC
22	COM
23	NEJ
31	NC
32	COM
33	NEJ
Startklar 250 V AC / 30 V DC 2 A	
Kører 250 V AC / 30 V DC 2 A	
Fejl(-1) 250 V AC / 30 V DC 2 A	
XD24 Digital interlock	
1	DIIL
2	+24VD
3	DICOM
4	+24VD
5	DIOGND
J6	J6
Start frigiv	
+24 V DC 200 mA	
Jording af digital indgang	
+24 V DC 200 mA	
Jording af digital indgang/udgang	
Afbryder til valg af jord	
XDIO Digitale indgange/udgange	
1	DIO1
2	DIO2
Udgang: Startklar	
Udgang: Kører	
XDI Digitale indgange	
1	DI1
2	DI2
3	DI3
4	DI4
5	DI5
6	DI6
Stop (0) / Start (1)	
Forlæns (0) / Baglæns (1)	
Nulstil	
Acceleration og deceleration vælg	
Konstant hastighed 1 (1 = Til)	
Som standardindstilling ubenyttet.	
XSTO Safe torque off	
1	OUT1
2	SGND
3	IN1
4	IN2
Safe torque off. Begge kredse skal være lukkede, for at frekvensomformeren kan starte.	
X12 Modulforbindelse med sikkerhedsfunktioner	
X13 Tilslutning til betjeningspanel	
X205 Tilslutning til hukommelsesenhed	

Overensstemmelseserklæring (EU)

Power and productivity
for a better world™



EU Declaration of Conformity

Machinery Directive 2006/42/EC

We

Manufacturer: ABB Oy
Address: Hiomotie 13, 00380 Helsinki, Finland.
Phone: +358 10 22 11

declare under our sole responsibility that the following products:

Frequency converters

ACS880-01

ACS880-04/-04F

ACS880-M04

ACS880-11/-31/-14/-34

with regard to the built-in safety function:

Safe torque off;

and with regard to the following optional safety functions with FSO-12 module (option code +Q973, encoderless):

Safe stop 1; Safe stop emergency; Safely-limited speed; Safe maximum speed; Safe brake control; Prevention of Unexpected Start-up;

and with regard to the following optional safety functions (option codes +Q972 and +L521, encoder supported):

Safe stop 1; Safe stop emergency; Safely-limited speed; Safe maximum speed; Safe brake control; Safe speed monitor; Safe direction; Prevention of Unexpected Start-up;

and with regard to the following optional safety function with FPTC-01 thermistor protection module (option code +L536):

Safe Motor Temperature;

are in conformity with all the relevant safety component requirements of EU Machinery Directive 2006/42/EC, when the listed safety functions are used for safety component functionality.

EU Declaration of Conformity

Machinery Directive 2006/42/EC

The following harmonized standards have been applied:

EN 61800-5-2:2007	<i>Adjustable speed electrical power drive systems – Part 5-2: Safety requirements - Functional</i>
EN 62061:2005 + AC:2010 + A1:2013 + A2:2015	<i>Safety of machinery – Functional safety of safety-related electrical, electronic and programmable electronic control systems</i>
EN ISO 13849-1:2015	<i>Safety of machinery – Safety-related parts of control systems. Part 1: General requirements</i>
EN ISO 13849-2:2012	<i>Safety of machinery – Safety-related parts of the control systems. Part 2: Validation</i>
EN 60204-1: 2006 + A1:2009 + AC:2010	<i>Safety of machinery – Electrical equipment of machines – Part 1: General requirements</i>

The following other standards have been applied:

IEC 61508:2010	<i>Functional safety of electrical / electronic / programmable electronic safety-related systems</i>
IEC 61800-5-2:2016	<i>Adjustable speed electrical power drive systems – Part 5-2: Safety requirements - Functional</i>

The products referred in this Declaration of conformity fulfil the relevant provisions of other European Union Directives which are notified in Single EU Declaration of conformity 3AXD10000497831.

Person authorized to compile the technical file:

Name and address: Juha Martinmaa, Hiomotie 13, 00380 Helsinki, Finland.

Helsinki, 15 Sep 2017

Manufacturer representative:



Vesa Kandell
Vice President, ABB Oy

DE – Kurzanleitung für die Installation

Diese Kurzanleitung beschreibt die Installation des Frequenzumrichters. Vollständige Informationen zur Installation siehe *ACS880-31 drives hardware manual* (3AXD50000045933 [Englisch]). Inbetriebnahmeanweisungen siehe *ACS880 drives with primary control program quick start-up guide* (3AUA0000098062 [Englisch]).

Die Handbücher finden Sie unter www.abb.com/drives/documents, und suchen Sie das Dokument mit seiner jeweiligen Dokumentennummer.

Befolgen Sie die Sicherheitsvorschriften



WARNUNG! Befolgen Sie diese Hinweise. Wenn diese nicht befolgt werden, können Verletzungen, tödliche Unfälle oder Schäden an den Geräten auftreten:

- Installation und Wartung des Frequenzumrichters dürfen nur von qualifiziertem Fachpersonal ausgeführt werden.
 - Am Frequenzumrichter, dem Motorkabel oder dem Motor dürfen keinerlei Arbeiten ausgeführt werden, solange die Netzspannung anliegt. Wenn der Frequenzumrichter bereits an die Spannungsversorgung angeschlossen ist/war, warten Sie 5 Minuten nach der Trennung von der Eingangsspannung.
 - Führen Sie keine Arbeiten an den Steuerkabeln durch, wenn Spannung am Frequenzumrichter oder den externen Steuerkreisen anliegt.
 - Am Frequenzumrichter keine Spannung anlegen, die höher ist, als auf dem Typenschild angegeben.
 - Erden Sie immer den Frequenzumrichter, den Motor und die benachbarten Geräte über die PE-Sammelschiene der Spannungsversorgung.
 - **Baugrößen R6 und R8:** Das Frequenzumrichtermodul ist schwer und hat einen hoch liegenden Schwerpunkt. Verwenden Sie eine Hebevorrichtung. Der Frequenzumrichter darf nicht gekippt werden. Das manuelle Anheben oder ein Umkippen kann zu Verletzungen führen. Stellen Sie sicher, dass die Wand und die Montagemittel das Gewicht tragen können.
 - Verhindern Sie, dass Bohrspäne, Schneidespäne oder Staub in den Frequenzumrichter eindringen.
 - Stellen Sie sicher, dass der Boden unterhalb des Frequenzumrichters und die Wand, an der der Frequenzumrichter montiert wird, aus nicht brennbarem Material bestehen.
-

Prüfen Sie, ob Kondensatoren nachformiert werden müssen

Wenn der Frequenzumrichter seit mehr als drei Jahren nicht an die Spannungsversorgung angeschlossen war (entweder gelagert oder nicht benutzt war), müssen die Kondensatoren nachformiert werden.

Das Herstellungsdatum kann anhand der Seriennummer bestimmt werden, welche auf dem am Frequenzumrichter angebrachten Typenschild angegeben ist. Die Seriennummer hat das Format MJJWWRXXXX. JJ und WW geben das Herstellungsjahr und die -woche an:

JJ: 17, 18, 19, ... für 2017, 2018, 2019, ...

WW: 01, 02, 03, ... für Woche 1, Woche 2, Woche 3, ...

Informationen zum Formieren der Kondensatoren enthält die Anleitung *Converter module capacitor reforming instructions* (3BFE64059629 [englisch]), verfügbar im Internet auf www.abb.com/drives/documents.

Daten

IEC-Nennwerten

ACS880-31	Kabel (mm ²)	aR-Sicherung	Verlustleistung (W)
3-phasig, $U_N = 400\text{ V}$ (380...415 V)			
09A4-3	3×1,5	170M1561	226
12A6-3	3×1,5	170M1561	329
017A-3	3×6	170M1563	395
025A-3	3×6	170M1563	579
032A-3	3×10	170M1565	625
038A-3	3×10	170M1565	751
045A-3	3×16	170M1566	912
061A-3	3×25	170M1567	1088
072A-3	3×35	170M1568	1502
087A-3	3×50	170M1569	1904
105A-3	3×50	170M3817	1877
145A-3	3×95	170M3817	2963
169A-3	3×120	170M5809	3168
206A-3	3×150	170M5810	3990
3-phasig, $U_N = 500\text{ V}$ (380...500 V)			
07A6-5	3×1,5	170M1561	219
11A0-5	3×1,5	170M1561	278
014A-5	3×6	170M1563	321
021A-5	3×6	170M1563	473
027A-5	3×10	170M1565	625
034A-5	3×10	170M1565	711
040A-5	3×16	170M1566	807
052A-5	3×25	170M1567	960
065A-5	3×35	170M1568	1223
077A-5	3×35	170M1569	1560
101A-5	3×50	170M3816	1995
124A-5	3×95	170M3817	2800
156A-5	3×120	170M5808	3168
180A-5	3×150	170M5810	3872

3AXD0000588487

DE

Auswahl der Leistungskabel

Siehe [Daten](#) auf Seite 29.

Ausreichende Kühlung sicherstellen

Siehe [Daten](#) auf Seite 29. Kondensation und/oder Vereisung sind nicht zulässig. Der zulässige Betriebstemperaturbereich für den Frequenzumrichter ohne Leistungsminderung beträgt -15 bis +40 °C.

Schutz des Frequenzumrichters und der Einspeisekabel

Siehe Abschnitt [Daten](#) auf Seite [29](#).

A – Wandmontage des Frequenzumrichters

Siehe Abbildung [A](#) auf Seite [137](#).

B – Die Abdeckung abnehmen.

Die Abdeckung(en) abnehmen. Siehe Abbildungen [B \(R3\)](#) und [B \(R6, R8\)](#)... auf Seite [137](#).

C – Prüfung der Kompatibilität mit IT- (ungeerdeten) und asymmetrisch geerdeten TN-Netzen

Siehe Abbildung [C](#) auf Seite [137](#).

DE

 **WARNUNG!** Wenn der Frequenzumrichter an ein IT- (ungeerdetes oder hochohmig geerdetes) Netz oder ein asymmetrisch geerdetes TN-Netz angeschlossen wird, muss der EMV-Filter (Option +E202) abgetrennt und der Erde-Phase-Varistor geerdet werden. Siehe das entsprechende Hardware-Handbuch des Frequenzumrichters.

D – Prüfung der Isolation der Einspeise- und Motorkabel und des Motors

Das Motorkabel motorseitig anschließen. Für minimale HF-Störungen muss der Motorkabelschirm an der Eingangsverschraubung des Motorklemmenkastens mit einer 360-Grad-Erdung versehen werden. Siehe Abbildung [D](#) auf Seite [137](#).

Prüfen Sie die Isolation des Motors und des Motorkabels. Siehe Abbildung [D](#) auf Seite [137](#). **Hinweis:** Feuchtigkeit innerhalb des Motorgehäuses reduziert den Isolationswiderstand. Bei Verdacht auf Feuchtigkeit den Motor trocknen und die Messung wiederholen.

Prüfen Sie die Isolation des Eingangskabels vor dem Anschluss an den Frequenzumrichter. Befolgen Sie die örtlichen Vorschriften.

E – Bringen Sie die Warnaufkleber in der Landessprache an

Siehe Abbildung [E](#) auf Seite [138](#).

F – Anschluss der Leistungskabel

Ein symmetrisch geschirmtes Motorkabel ist zu verwenden. Wenn der Kabelschirm der einzige PE-Leiter ist, stellen Sie sicher, dass er eine ausreichend bemessene Leitfähigkeit für PE hat.

Hinweis für Baugröße R3: Stellen Sie sicher, dass sie einen zusätzlichen PE-Leiter im Einspeisekabel haben. Weitere Informationen enthält das Hardware-Handbuch.

Vorgehensweise:

1. Baugrößen R6 und R8: Die Abdeckung von den Leistungskabelklemmen entfernen. Siehe Abbildung *F (R6, R8)*... auf Seite 138. Baugröße R8: Entfernen Sie für eine leichtere Montage die Seitenbleche.
2. Die Gummi-Kabeldurchführungen für die anzuschließenden Kabel aus dem Bodenblech entfernen. Siehe Abbildung *...F...* auf Seite 138.
3. Eine passende Öffnung in die Gummidichtung schneiden. Kabeldurchführungen auf die Kabel schieben.
4. Die Kabelenden vorbereiten. Siehe Abbildung *...F...* auf Seite 138.
Der blanke Schirm des Kabels wird 360 Grad geerdet. Kennzeichnen Sie das verdrehte Schirmbündel als PE-Leiter mit einer gelb-grünen Markierung.
Es werden zwei alternative symmetrische Drei-Leiter-Kabeltypen und ein Vier-Leiter-Kabeltyp gezeigt. Das Vier-Leiter-Kabel ist nur für die Eingangsverkabelung zulässig.
Wenn Sie Aluminiumkabel verwenden, versehen Sie den abisolierten Teil mit Kontaktfett, bevor Sie das Kabel an den Frequenzumrichter anschließen.
5. Die Kabel durch die Öffnungen der Kabeleinführungsplatte stecken und die Dichtungen in die Öffnungen drücken.
6. Die Kabel anschließen (verwenden Sie die in der Abbildung angegebenen Anzugsmomente). Siehe Abbildungen *...F...* auf Seite 138 und 139:
 - Den Schirm 360 erden, indem die Kabelschelle der Einspeisekabelerdung über den abisolierten Teil gelegt und verschraubt wird.
 - Den verdrehten Schirm des Kabels an die Erdungsklemme anschließen.
 - Verwenden Sie ein separates PE-Erdungskabel (6a) oder ein Kabel mit separatem PE-Leiter (6b), wenn die Leitfähigkeit des Schirms den Anforderungen an den PE-Leiter nicht genügt. Wenn der PE-Leiter einen kleineren Querschnitt als 10 mm² aufweist, muss ein zweiter Erdleiter verwendet werden. Weitere Informationen enthält das Hardware-Handbuch.
 - Baugröße R3: Den zusätzlichen PE-Leiter des Eingangskabels anschließen.
 - Die Phasenleiter des Motorkabels an die Klemmen T1/U, T2/V und T3/W und die Phasenleiter des Eingangskabels an die Klemmen L1, L2 und L3 anschließen.

7. Bei Baugröße R6 und Typen größer als -040A-x: Machen Sie Ausschnitte in die Abdeckung für die installierten Kabel. Baugröße R8: Befestigen Sie wieder die Seitenbleche, falls diese entfernt wurden. Brechen Sie aus der Abdeckung Öffnungen für die Eingangskabel heraus. Siehe Abbildung ...F (R6, R8)... auf Seite 139.
8. Baugrößen R6 und R8: Die Abdeckung über den Leistungskabelklemmen montieren. Siehe Abbildung ...F (R6, R8)... auf Seite 139.
9. Die Kabel außerhalb des Frequenzumrichters mechanisch sichern.

G – Anschluss der Steuerkabel

Vorgehensweise:

1. Entfernen Sie die Frontabdeckung(en), falls noch nicht geschehen.
2. Baugröße R3: Den Bedienpanelhalter hochklappen. Siehe Abbildung G (R3)... auf Seite 139.
3. Schneiden Sie eine passende Öffnung in die Gummi-Kabeldurchführung und schieben Sie die Kabeldurchführung auf das Kabel. Das Kabel durch eine Öffnung der Bodenplatte stecken und die Kabeldurchführung in die Öffnung drücken.
4. Verlegen Sie die Kabel. Baugröße R3: Siehe Abbildung ...G (R3)... auf Seite 139. Baugröße R6: Siehe Abbildung ...G (R6)... auf Seite 139. Baugröße R8: Siehe Abbildung ...G (R8)... auf Seite 140.
5. Eine 360-Grad-Erdung des Kabelschirms unter der Erdungsschelle durchführen. Das Kabel mit durchgängigem Schirm so nahe wie möglich an die Klemmen der Regelungseinheit führen.
6. Die Kabel innerhalb des Frequenzumrichters mechanisch sichern.
7. Baugröße R3: Schließen Sie die Kabelschirme und die Erdleiter antriebsseitig nicht an und erden Sie diese am anderen Ende der Leiterpaare des Kabels. Schneiden Sie nicht angeschlossene Leiter auf der Antriebsseite ab. Baugröße R6 und R8: Die Kabelschirme und den Erdleiter unter der Schelle unterhalb der Regelungseinheit erden.
8. Schließen Sie die Leiter an die entsprechenden Klemmen der Regelungseinheit an. Siehe [Standard-E/A-Anschlussplan](#) auf Seite 34.
9. Die Optionsmodule, falls im Lieferumfang enthalten, verdrahten. Siehe das Benutzerhandbuch des Optionsmoduls oder die Installationsanleitung.
10. Die Kabel außerhalb des Frequenzumrichters mechanisch sichern.

Hinweis:

- Schließen Sie die anderen Enden der Steuerkabelschirme nicht an
 - Signalleiterpaare bis auf den kürzestmöglichen Abstand zu den Klemmen verdreht lassen.
-

H – Abdeckung(en) wieder installieren

Siehe Abbildungen [H \(R3, R6, R8\)](#)... auf Seite [140](#).

■ Standard-E/A-Anschlussplan

Leitergrößen:
0,5 ... 2,5 mm²
(24... 14 AWG)
Anzugsmoment:
0,5 Nm
(0,4 lbf-ft) für
Litzen und
einadrige Leiter.

XPOW Eingang für externe Spannungsversorgung

1	+24VI	24 V DC, 2 A
2	GND	

XAI Referenzspannungs- und Analogeingänge

1	+VREF	10 V DC, R_i 1...10 kOhm
2	-VREF	-10 V DC, R_i 1...10 kOhm
3	AGND	Masse
4	AI1+	Drehzahl-Sollwert
5	AI1-	0(2)...10 V, R_{in} > 200 kOhm
6	AI2+	Standardmäßig nicht benutzt.
7	AI2-	0(4)...20 mA, R_{in} = 100 Ohm
J1	J1	AI1 Steckbrücke für Auswahl I/U Strom/Spannung
J2	J2	AI2 Steckbrücke für Auswahl I/U Strom/Spannung

XAO Analogausgänge

1	AO1	Motordrehzahl U/min
2	AGND	0...20 mA, R_i < 500 Ohm
3	AO2	Motorstrom
4	AGND	0...20 mA, R_i < 500 Ohm

XD2D Umrichter-Umrichter-Verbindung (D2D)

1	B	Umrichter-Umrichter-Verbindung (D2D)
2	A	
3	BGND	
J3	J3	Schalter Abschluss Drive-to-Drive

XRO1, XRO2, XRO3 Relaisausgänge

11	NC	Bereit
12	COM	250 V AC / 30 V DC
13	NO	2 A
21	NC	Läuft
22	COM	250 V AC / 30 V DC
23	NO	2 A
31	NC	Störung (-1)
32	COM	250 V AC / 30 V DC
33	NO	2 A

XD24 Digital-Startsperre

1	DIIL	Reglerfreigabe
2	+24VD	+24 V DC 200 mA
3	DICOM	Digitaleingang Masse
4	+24VD	+24 V DC 200 mA
5	DIOGND	Digitaleingang/-ausgang Masse
J6	J6	Schalter Masse-Auswahl

XDIO Digitaleingänge/-ausgänge

1	DIO1	Ausgang: Bereit
2	DIO2	Ausgang: Läuft

XDI Digitaleingänge

1	DI1	Stopp (0) / Start (1)
2	DI2	Vorwärts (0) / Rückwärts (1)
3	DI3	Rücksetzen
4	DI4	Auswahl Beschl./Verzög.-Rampen
5	DI5	Konstantdrehzahl 1 (1 = Ein)
6	DI6	Standardmäßig nicht benutzt.

XSTO Sicher abgeschaltetes Drehmoment

1	OUT1	Sicher abgeschaltetes Drehmoment (STO). Beide Kreise müssen für den Start des Antriebs geschlossen sein.
2	SGND	
3	IN1	
4	IN2	

X12 Sicherheitsfunktionsmodul-Anschluss

X13 Bedienpanel-Anschluss

X205 Anschluss für Memory Unit

DE

Konformitätserklärung (EU)

Power and productivity
for a better world™ 

EU Declaration of Conformity

Machinery Directive 2006/42/EC

We

Manufacturer: ABB Oy
Address: Hiomotie 13, 00380 Helsinki, Finland.
Phone: +358 10 22 11

declare under our sole responsibility that the following products:

Frequency converters

ACS880-01

ACS880-04/-04F

ACS880-M04

ACS880-11/-31/-14/-34

with regard to the built-in safety function:

Safe torque off;

and with regard to the following optional safety functions with FSO-12 module (option code +Q973, encoderless):

Safe stop 1; Safe stop emergency; Safely-limited speed; Safe maximum speed; Safe brake control; Prevention of Unexpected Start-up;

and with regard to the following optional safety functions (option codes +Q972 and +L521, encoder supported):

Safe stop 1; Safe stop emergency; Safely-limited speed; Safe maximum speed; Safe brake control; Safe speed monitor; Safe direction; Prevention of Unexpected Start-up;

and with regard to the following optional safety function with FPTC-01 thermistor protection module (option code +L536):

Safe Motor Temperature;

are in conformity with all the relevant safety component requirements of EU Machinery Directive 2006/42/EC, when the listed safety functions are used for safety component functionality.

EU Declaration of Conformity

Machinery Directive 2006/42/EC

The following harmonized standards have been applied:

EN 61800-5-2:2007	<i>Adjustable speed electrical power drive systems – Part 5-2: Safety requirements - Functional</i>
EN 62061:2005 + AC:2010 + A1:2013 + A2:2015	<i>Safety of machinery – Functional safety of safety-related electrical, electronic and programmable electronic control systems</i>
EN ISO 13849-1:2015	<i>Safety of machinery – Safety-related parts of control systems. Part 1: General requirements</i>
EN ISO 13849-2:2012	<i>Safety of machinery – Safety-related parts of the control systems. Part 2: Validation</i>
EN 60204-1: 2006 + A1:2009 + AC:2010	<i>Safety of machinery – Electrical equipment of machines – Part 1: General requirements</i>

The following other standards have been applied:

IEC 61508:2010	Functional safety of electrical / electronic / programmable electronic safety-related systems
IEC 61800-5-2:2016	Adjustable speed electrical power drive systems – Part 5-2: Safety requirements - Functional

The products referred in this Declaration of conformity fulfil the relevant provisions of other European Union Directives which are notified in Single EU Declaration of conformity 3AXD10000497831.

Person authorized to compile the technical file:

Name and address: Juha Martinmaa, Hiomotie 13, 00380 Helsinki, Finland.

Helsinki, 15 Sep 2017

Manufacturer representative:



Vesa Kandell
Vice President, ABB Oy

ES – Guía rápida de instalación

Esta guía describe brevemente cómo instalar el convertidor de frecuencia. Consulte la documentación completa sobre la instalación en *ACS880-31 drives hardware manual* (3AXD50000045933 [Inglés]). Consulte las instrucciones de puesta en marcha en *ACS880 drives with primary control program quick start-up guide* (3AUA0000098062 [Inglés]).

Para consultar un manual, entre en www.abb.com/drives/documents y busque el número del documento.

Siga estrictamente las instrucciones de seguridad



ADVERTENCIA: Siga estrictamente estas instrucciones. Si no lo hace, se pueden producir daños en el equipo o en las personas, e incluso causar la muerte:

- Sólo podrán efectuar la instalación y el mantenimiento del convertidor electricistas cualificados.
- No intente trabajar con el convertidor, el cable de motor o el motor con la alimentación principal conectada. Si el convertidor está conectado a la potencia de entrada, espere 5 minutos tras desconectarlo.
- Nunca manipule los cables de control mientras el convertidor o los circuitos de control externo reciban alimentación.
- No conecte el convertidor a una tensión superior a la indicada en la etiqueta de designación de tipo.
- Conecte siempre el convertidor, el motor y los equipos auxiliares al embarrado de conexión a tierra (PE) de la fuente de alimentación.
- Bastidores R6 y R8: El módulo de convertidor es pesado y su centro de gravedad está alto. Use un dispositivo de elevación para el izado. No incline el convertidor. El izado manual o el vuelco al inclinarlo podrían producir lesiones. Asegúrese de que la pared y los dispositivos de fijación puedan soportar el peso.
- Asegúrese de que no entren en el convertidor los restos resultantes de taladrar, cortar y pulir.
- Asegúrese de que el suelo sobre el que se apoya el convertidor y la pared sobre la que está instalado son ignífugos.

Compruebe si es necesario reacondicionar los condensadores

Si el convertidor no ha recibido alimentación (estando almacenado o fuera de uso) durante más de tres años, deberá reacondicionar los condensadores.

Puede determinar la fecha de fabricación a partir del número de serie, que encontrará en la etiqueta de designación de tipo adherida al convertidor. El número de serie tiene el formato MAASSRXXXX. AA y SS indican el año y la semana de fabricación, de la forma siguiente:

AA: 17, 18, 19... para 2017, 2018, 2019...

SS: 01, 02, 03... para semana 1, semana 2, semana 3...

Para más información sobre el reacondicionamiento de los condensadores, consulte el documento *Converter module capacitor reforming instructions* (3BFE64059629 [Inglés]), disponible en Internet en www.abb.com/drives/documents.

Datos técnicos

Especificaciones IEC

ACS880-31	Cable (mm ²)	Fusible aR	Pérdidas (W)
Trifásico $U_N = 400\text{ V}$ (380...415 V)			
09A4-3	3×1,5	170M1561	226
12A6-3	3×1,5	170M1561	329
017A-3	3×6	170M1563	395
025A-3	3×6	170M1563	579
032A-3	3×10	170M1565	625
038A-3	3×10	170M1565	751
045A-3	3×16	170M1566	912
061A-3	3×25	170M1567	1088
072A-3	3×35	170M1568	1502
087A-3	3×50	170M1569	1904
105A-3	3×50	170M3817	1877
145A-3	3×95	170M3817	2963
169A-3	3×120	170M5809	3168
206A-3	3×150	170M5810	3990
Trifásico $U_N = 500\text{ V}$ (380...500 V)			
07A6-5	3×1,5	170M1561	219
11A0-5	3×1,5	170M1561	278
014A-5	3×6	170M1563	321
021A-5	3×6	170M1563	473
027A-5	3×10	170M1565	625
034A-5	3×10	170M1565	711
040A-5	3×16	170M1566	807
052A-5	3×25	170M1567	960
065A-5	3×35	170M1568	1223
077A-5	3×35	170M1569	1560
101A-5	3×50	170M3816	1995
124A-5	3×95	170M3817	2800
156A-5	3×120	170M5808	3168
180A-5	3×150	170M5810	3872

Selección de los cables de potencia

Véase *Datos técnicos* en la página 38.

Garantizar la refrigeración

Véase *Datos técnicos* en la página 38. No se permite condensación ni escarcha. El rango de temperatura de funcionamiento permitido para el convertidor de frecuencia sin pérdidas de potencia es de -15 a +40 °C.

Protección del convertidor y el cable de potencia de entrada

Véase *Datos técnicos* en la página 38.

A – Montaje del convertidor de frecuencia en la pared

Véase la figura A en la página 137.

B – Retirar la cubierta

Retire la/s cubierta/s. Consulte las figuras B (R3) y B (R6, R8)... en la página 137.

C – Comprobar la compatibilidad con las redes IT (sin conexión a tierra) y redes con conexión a tierra en un vértice

Véase la figura C en la página 137.



ADVERTENCIA: Si el convertidor se va a conectar a una red IT (sin conexión a tierra o con conexión a tierra de alta resistencia) o a una red con conexión a tierra en un vértice, desconecte el filtro EMC (opcional +E202) y el varistor tierra-fase. Consulte el manual de hardware del convertidor.

D – Comprobar el aislamiento de los cables de potencia y del propio motor

Conecte el cable de motor del lado del motor. Para que las interferencias por radiofrecuencia sean mínimas, conecte a tierra a 360 grados la pantalla del cable de motor en la entrada de cable de la caja de terminales del motor. Véase la figura D en la página 137.

Comprobar el aislamiento del motor y del cable de motor. Véase la figura D en la página 137. **Nota:** La humedad en el interior de la carcasa del motor reduce la resistencia de aislamiento. Si sospecha de la presencia de humedad, seque el motor y repita la medición.

Comprobar el aislamiento del cable de alimentación antes de conectarlo al convertidor. Siga los reglamentos locales.

E – Fijar las etiquetas de advertencia disponibles en los idiomas locales

Véase la figura [E](#) en la página [138](#).

F – Conectar los cables de potencia

Use cable apantallado simétrico para el cableado al motor. Si la pantalla del cable es el único conductor de conexión a tierra, asegúrese de que tiene la conductividad suficiente como para ofrecer una protección adecuada de este tipo.

Nota acerca del bastidor R3: Asegúrese de tener un conductor de conexión a tierra adicional en el cableado de potencia de entrada. Consulte el manual de hardware para obtener más información.

Procedimiento:

ES

1. Bastidor R6 y R8: Retire la cubierta protectora de los terminales del cable de potencia. Véase la figura [F \(R6, R8\)](#)... en la página [138](#). Bastidor R8: Para facilitar la instalación, retire los paneles laterales.
2. Retire las arandelas de goma de la placa inferior para los cables que desee conectar. Véase la figura [...F...](#) en la página [138](#).
3. Recorte un orificio adecuado en los pasacables de goma. Deslice los pasacables por los cables.
4. Prepare los extremos de los cables. Véase la figura [...F...](#) en la página [138](#).

La pantalla pelada se conecta a tierra a 360 grados. Marque el extremo del cable de la pantalla con colores verde y amarillo para indicar que es el conductor de conexión a tierra.

Se muestran dos tipos alternativos cables de tres conductores simétricos y un tipo de cable de cuatro conductores. Sólo se permite el uso del cable de cuatro conductores para el cableado de potencia de entrada.

Si utiliza cables de aluminio, ponga grasa en el cable pelado de aluminio antes de conectarlo al convertidor.

5. Pase los cables a través de los orificios de la placas de entrada de cables y fije las arandelas a los orificios.
6. Conecte los cables (use los pares definidos en la figura). Véanse las figuras [...F...](#) en la página [138](#) y [139](#):
 - Conecte a tierra la pantalla a 360 grados apretando la abrazadera de la pletina de conexión a tierra del cable de potencia en la parte pelada del cable.

- Conecte el apantallamiento trenzado del cable al terminal de conexión a tierra.
 - Use un cable PE con conexión a tierra separada (6a) o un cable con un conductor PE separado (6b) si la conductividad de la pantalla no cumple los requisitos del conductor de conexión a tierra. Si el conductor de conexión a tierra de protección es de menos de 10 mm^2 , deberá usar un segundo conductor de conexión a tierra. Consulte el manual de hardware para obtener más información.
 - **Bastidor R3:** Conecte el conductor de conexión a tierra adicional del cableado de potencia de entrada.
 - Conecte los conductores de fase del cable de motor a los terminales T1/U, T2/V y T3/W y los conductores de fase del cable de alimentación a los terminales L1, L2 y L3.
7. **Tipos de bastidores R6 mayores que -040A-x:** Corte lengüetas en la cubierta protectora para los cables instalados. **Bastidor R8:** Si retiró los paneles laterales, móntelos. Practique orificios en la cubierta protectora para los conductores del cable de alimentación. Véase la figura *...F (R6, R8)...* en la página 139.
 8. **Bastidores R6 y R8:** Monte la cubierta protectora en los terminales del cable de potencia. Véase la figura *...F (R6, R8)...* en la página 139.
 9. Fije los cables fuera del convertidor de forma mecánica.

G – Conexión de los cables de control

Procedimiento:

1. Retire la cubierta o cubiertas frontales si no lo ha hecho antes.
2. **Bastidor R3:** Eleve el soporte del panel de control. Véase la figura *G (R3)...* en la página 139.
3. Practique un orificio adecuado en el pasacables de goma y pase el cable a través de él. Pase el cable a través de un orificio de la placa pasacables y fije el pasacables en el orificio.
4. Enrutar los cables. **Bastidor R3:** Véase la figura *...G (R3)...* en la página 139. **Bastidor R6:** Véase la figura *...G (R6)...* en la página 139. **Bastidor R8:** Véase la figura *...G (R8)...* en la página 140.
5. Conecte a tierra la pantalla exterior del cable a 360 grados bajo la abrazadera de conexión a tierra. Mantenga el cable apantallado lo más cerca posible de los terminales de la tarjeta de control.
6. Fije los cables dentro del convertidor de forma mecánica.
7. **Bastidor R3:** En el extremo del convertidor de frecuencia, deje sin conectar las pantallas de los cables de pares trenzados y los cables de conexión a tierra y conéctelos a tierra en el otro extremo del cable. Corte los cables no conectados

del extremo del convertidor. Bastidor R6 y R8: conecte a tierra las pantallas de los cables de par trenzado apantallados y el cable de conexión a tierra bajo la abrazadera situada debajo de la unidad de control.

8. Conecte los conductores a los terminales apropiados de la unidad de control. Véase *Diagrama de conexiones de E/S por defecto* en la página 43.
9. Cablee los módulos opcionales si están incluidos en el suministro. Consulte el manual de usuario o la guía de instalación del módulo opcional.
10. Fije los cables fuera del convertidor de forma mecánica.

Nota:

- Deje sin conectar los otros extremos de las pantallas de los cables de control.
- Mantenga trenzados los pares de hilos de señal lo más cerca posible de los terminales.

H – Montar de nuevo la(s) cubierta(s)

Véanse las figuras *H (R3, R6, R8)*... en la página 140.

■ Diagrama de conexiones de E/S por defecto

Tamaños de hilos:
0,5 ... 2,5 mm²
(24...14 AWG)
Pares de apriete: 0,5 N·m
(0,4 lbf·ft) tanto para los cables flexibles como para los rígidos.

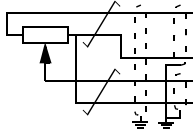

XPOW Entrada de alimentación externa		
1	+24 VI	24 V CC, 2 A
2	GND	
XAI Tensión de referencia y entradas analógicas		
1	+VREF	10 V CC, R_1 1...10 kohmios
2	-VREF	-10 V CC, R_1 1...10 kohmios
3	AGND	Tierra
4	AI1+	Ref. de velocidad 0(2)...10 V, R_{in} > 200 kohmios
5	AI1-	
6	AI2+	Por defecto no se usa. 0(4)...20 mA, R_{in} = 100 ohmios
7	AI2-	
J1	J1	Puente de selección de Tensión/Corriente AI1
J2	J2	Puente de selección de Tensión/Corriente AI2

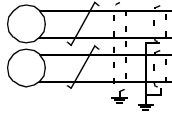

XAO Salidas analógicas		
1	AO1	Régimen de motor rpm 0...20 mA, R_L < 500 ohmios
2	AGND	
3	AO2	Intensidad de motor 0...20 mA, R_L < 500 ohmios
4	AGND	

XD2D Enlace de convertidor a convertidor		
1	B	Enlace de convertidor a convertidor
2	A	
3	BGND	
J3	J3	Terminador de enlace de convertidor a convertidor

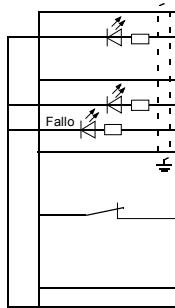

XRO1, XRO2, XRO3 Salidas de relé		
11	NC	Listo 250 V CA / 30 V CC 2 A
12	COM	
13	NA	En marcha 250 V CA / 30 V CC 2 A
21	NC	
22	COM	Fallo(-1) 250 V CA / 30 V CC 2 A
23	NA	
31	NC	Fallo(-1) 250 V CA / 30 V CC 2 A
32	COM	
33	NA	

XD24 Bloqueo de marcha		
1	DIIL	Permiso de marcha
2	+24 VD	+24 V CC 200 mA
3	DICOM	Tierra de entrada digital
4	+24 VD	+24 V CC 200 mA
5	DIOGND	Tierra de entrada/salida digital
J6	J6	Interruptor de selección de tierra

XDIO Entradas/salidas digitales		
1	DIO1	Salida: Listo
2	DIO2	Salida: En marcha

XDI Entradas digitales		
1	DI1	Paro (0) / Marcha (1)
2	DI2	Avance (0) / Retroceso (1)
3	DI3	Restaurar
4	DI4	Selección de aceleración y deceleración
5	DI5	Velocidad constante 1 (1 = activado)
6	DI6	Por defecto no se usa.

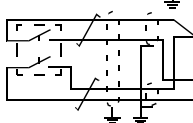

XSTO Safe Torque Off		
1	OUT1	Safe Torque Off. Ambos circuitos deben estar cerrados para que el convertidor pueda ponerse en marcha.
2	SGND	
3	IN1	
4	IN2	

X12	Conexión de módulo de funciones de seguridad	
X13	Conexión del panel de control	
X205	Conexión de la unidad de memoria	

Declaración de conformidad (UE)

Power and productivity
for a better world™



EU Declaration of Conformity

Machinery Directive 2006/42/EC

We

Manufacturer: ABB Oy
Address: Hiomotie 13, 00380 Helsinki, Finland.
Phone: +358 10 22 11

declare under our sole responsibility that the following products:

Frequency converters

ACS880-01

ACS880-04/-04F

ACS880-M04

ACS880-11/-31/-14/-34

with regard to the built-in safety function:

Safe torque off;

and with regard to the following optional safety functions with FSO-12 module (option code +Q973, encoderless):

Safe stop 1; Safe stop emergency; Safely-limited speed; Safe maximum speed; Safe brake control; Prevention of Unexpected Start-up;

and with regard to the following optional safety functions (option codes +Q972 and +L521, encoder supported):

Safe stop 1; Safe stop emergency; Safely-limited speed; Safe maximum speed; Safe brake control; Safe speed monitor; Safe direction; Prevention of Unexpected Start-up;

and with regard to the following optional safety function with FPTC-01 thermistor protection module (option code +L536):

Safe Motor Temperature;

are in conformity with all the relevant safety component requirements of EU Machinery Directive 2006/42/EC, when the listed safety functions are used for safety component functionality.

Power and productivity
for a better world™



EU Declaration of Conformity

Machinery Directive 2006/42/EC

The following harmonized standards have been applied:

EN 61800-5-2:2007	<i>Adjustable speed electrical power drive systems – Part 5-2: Safety requirements - Functional</i>
EN 62061:2005 + AC:2010 + A1:2013 + A2:2015	<i>Safety of machinery – Functional safety of safety-related electrical, electronic and programmable electronic control systems</i>
EN ISO 13849-1:2015	<i>Safety of machinery – Safety-related parts of control systems. Part 1: General requirements</i>
EN ISO 13849-2:2012	<i>Safety of machinery – Safety-related parts of the control systems. Part 2: Validation</i>
EN 60204-1: 2006 + A1:2009 + AC:2010	<i>Safety of machinery – Electrical equipment of machines – Part 1: General requirements</i>

The following other standards have been applied:

IEC 61508:2010	Functional safety of electrical / electronic / programmable electronic safety-related systems
IEC 61800-5-2:2016	Adjustable speed electrical power drive systems – Part 5-2: Safety requirements - Functional

The products referred in this Declaration of conformity fulfil the relevant provisions of other European Union Directives which are notified in Single EU Declaration of conformity 3AXD10000497831.

Person authorized to compile the technical file:

Name and address: Juha Martinmaa, Hiomotie 13, 00380 Helsinki, Finland.

Helsinki, 15 Sep 2017

Manufacturer representative:

Vesa Kandell
Vice President, ABB Oy

FI – Asennuksen pikaopas

Tässä oppaassa on taajuusmuuttajan lyhyet asennusohjeet. Täydelliset tiedot asennuksesta on annettu oppaassa *ACS880-31 drives hardware manual* (3AXD5000045933, englanninkielinen). Käyttöönotto-ohjeet ovat oppaassa *ACS880 drives with primary control program quick start-up guide* (3AUA0000098062, englanninkielinen).

Voit lukea oppaita osoitteessa www.abb.com/drives/documents. Löydät oikean oppaan asiakirjanumerolla.

Noudata turvaohjeita



VAROITUS! Noudata näitä ohjeita. Ohjeiden laiminlyönti voi aiheuttaa fyysisen vamman tai hengenvaaran tai vahingoittaa laitteistoa.

- Taajuusmuuttajan asennus- ja huoltotyöt saa suorittaa vain valtuutettu sähköalan ammattilainen.
- Tee kaikki taajuusmuuttajan, moottorikaapelin ja moottorin asennus- ja huoltotyöt jännitteen ollessa katkaistuna. Jos taajuusmuuttaja on jo kytketty syöttöverkkoon, kytke se irti verkosta ja odota 5 minuuttia.
- Älä käsittele ohjauskaapeleita, kun taajuusmuuttajaan tai ulkosiin ohjauspiireihin on kytketty jännite.
- Älä kytke taajuusmuuttajaa tyyppikilpeen merkittyä jännitettä suurempaan jännitteeseen.
- Maadoita taajuusmuuttaja, moottori ja niihin liittyvät laitteet aina syötön suojamaakiskoon (PE).
- Runkokoot R6 ja R8: Taajuusmuuttaja on raskas, ja sen painopiste on korkealla. Käytä nostamiseen asianmukaista nostolaitetta. Älä kallista taajuusmuuttajaa. Taajuusmuuttajan nostaminen käsin voi johtaa loukkaantumiseen. Taajuusmuuttaja voi myös kaatua, jos se pääsee kallistumaan. Varmista, että seinä ja kiinnitysvälineet kestävät painon.
- Varmista, ettei poraus-, jyrä- tai hiontajätettä pääse laitteen sisään.
- Varmista, että taajuusmuuttajan alla oleva lattia ja seinä, johon taajuusmuuttaja on asennettu, ovat syttymättömiä.

FI

Tarkista, täytyykö kondensaattorit elvyttää

Jos taajuusmuuttajaan ei ole kytketty virtaa (eli se on ollut varastossa tai käyttämättömänä) yli kolmeen vuoteen, kondensaattorit on elvytettävä.

Voit selvittää valmistusajankohdan sarjanumeron perusteella. Sarjanumero on taajuusmuuttajaan kiinnitettyssä tyyppikilvessä. Sarjanumero on muotoa MYYWWRXXXX. YY ja WW ilmaisevat valmistusvuoden ja -viikon seuraavasti:

YY: 17, 18, 19, ..., mikä tarkoittaa vuotta 2017, 2018, 2019, ...

WW: 01, 02, 03, ..., mikä tarkoittaa viikkoa 1, 2, 3, ...

Lisätietoja kondensaattorien elvyttämisestä on *Converter module capacitor reforming instructions* -oppaassa (3BFE64059629, englanninkielinen), joka on saatavana osoitteesta www.abb.com/drives/documents.

Tieto

IEC-nimellisarvot

ACS880-31	Kaapeli (mm ²)	aR-sulake	Häviöt (W)
3-vaihe $U_N = 400\text{ V}$ (380...415 V)			
09A4-3	3 × 1,5	170M1561	226
12A6-3	3 × 1,5	170M1561	329
017A-3	3 × 6	170M1563	395
025A-3	3 × 6	170M1563	579
032A-3	3 × 10	170M1565	625
038A-3	3 × 10	170M1565	751
045A-3	3 × 16	170M1566	912
061A-3	3 × 25	170M1567	1088
072A-3	3 × 35	170M1568	1502
087A-3	3 × 50	170M1569	1904
105A-3	3 × 50	170M3817	1877
145A-3	3 × 95	170M3817	2963
169A-3	3 × 120	170M5809	3168
206A-3	3 × 150	170M5810	3990
3-vaihe $U_N = 500\text{ V}$ (380...500 V)			
07A6-5	3 × 1,5	170M1561	219
11A0-5	3 × 1,5	170M1561	278
014A-5	3 × 6	170M1563	321
021A-5	3 × 6	170M1563	473
027A-5	3 × 10	170M1565	625
034A-5	3 × 10	170M1565	711
040A-5	3 × 16	170M1566	807
052A-5	3 × 25	170M1567	960
065A-5	3 × 35	170M1568	1223
077A-5	3 × 35	170M1569	1560
101A-5	3 × 50	170M3816	1995
124A-5	3 × 95	170M3817	2800
156A-5	3 × 120	170M5808	3168
180A-5	3 × 150	170M5810	3872

3AXD00000588487

Valitse tehokaapelit

Katso *Tieto* sivulla 48.

Varmista jäähdytys

Katso [Tieto](#) sivulla [48](#). Tiivistyminen ja huurtuminen eivät ole sallittuja. Taajuusmuuttajan sallittu käyttölämpötila-alue ilman kuormitettavuuden alennusta on $-15...+40$ °C.

Suojaa taajuusmuuttaja ja syöttökaapeli

Katso [Tieto](#) sivulla [48](#).

A – Asenna taajuusmuuttaja seinälle

Katso kuva [A](#) sivulla [137](#).

B – Poista suojakansi

Poista suojakansi tai -kannet. Katso kuvat [B \(R3\)](#) ja [B \(R6, R8\)](#)... sivulla [137](#).

C – Tarkista yhteensopivuus maadoittamattomien IT-verkkojen ja epäsymmetrisesti maadoitettujen kolmiojärjestelmien kanssa

Katso kuva [C](#) sivulla [137](#).



VAROITUS! Jos taajuusmuuttaja asennetaan IT-verkkoon (maadoittamaton tai suurohmisesti maadoitettu verkko) tai epäsymmetrisesti maadoitettuun kolmiojärjestelmään, irrota EMC-suodin (lisävaruste +E202) ja maajohtimen ja vaihejohtimen välissä oleva varistori. Lisätietoja on taajuusmuuttajan laiteoppaassa.

D – Tarkista tehokaapelien ja moottorin eristys

Kytke moottorikaapeli moottorin päässä. Vähennä radiotaajuisia häiriöitä maadoittamalla moottorikaapelin suojavaippa 360 astetta moottorin kytkentäkotelon läpiviennissä. Katso kuva [D](#) sivulla [137](#).

Tarkista moottorin ja moottorikaapelin eristys. Katso kuva [D](#) sivulla [137](#). **Huomaa:** Moottorin kotelon sisällä oleva kosteus pienentää eristysvastusta. Jos epäilet, että kotelon sisällä on kosteutta, kuivata moottori ja toista mittaus.

Tarkista syöttökaapelin eristys ennen ennen sen kytkemistä taajuusmuuttajaan. Noudata paikallisia määräyksiä.

E – Kiinnitä tarrat, joissa varoitukset on annettu paikallisilla kielillä

Katso kuva [E](#) sivulla [138](#).

F – Kytke tehokaapelit

Käytä suojattua symmetristä moottorikaapelia. Jos kaapelin suojavaippa on ainoa PE-johdin, varmista, että sen johtavuus riittää suojavaadoitukseen.

Huomautus, runkokoko R3: Varmista, että syöttökaapeleissa on oma maajohdin. Lisätietoja on laiteoppaassa.

Toiminta:

1. Runkokoot R6 ja R8: Poista syöttökaapelin liittimien suojus. Katso kuva [F \(R6, R8\)...](#) sivulla [138](#). Runkokoko R8: Irrota sivulevyt, jotta asennus käy helpommin.
2. Irrota kumitiivisteet pohjalevystä kytkettäviä kaapeleita varten. Katso kuva [...F...](#) sivulla [138](#).
3. Leikkaa kumitiivistesiiin sopivan kokoiset reiät. Vedä tiivisteet kaapeleiden päälle.
4. Valmistele kaapelien päät. Katso kuva [...F...](#) sivulla [138](#).

Paljas vaippa maadoitetaan 360 astetta. Merkitse suojavaipasta tehty punos PE-johtimeksi keltavihreällä värillä.

Kuvassa näkyy kaksi vaihtoehtoista symmetristä kolmejohtimista kaapelityyppiä sekä yksi nelijohtiminen kaapelityyppi. Nelijohtimista kaapelia voi käyttää vain syöttökaapeloinnissa.

Jos käytetään alumiinikaapeleita, rasvaa kuorittu kaapeli ennen taajuusmuuttajaan kytkemistä.

5. Vie kaapelit kaapelien läpivientilevyssä olevien reikien läpi ja kiinnitä kumitiivisteet reikiin.
6. Kytke kaapelit. Katso kiristysmomentit kuvasta. Katso kuvat [...F...](#) sivulla [138](#) ja [139](#):
 - Maadoita suojavaippa 360 astetta kiristämällä syöttökaapelin maadoitusshyllyn kiinnike kaapelin kuorittuun osaan.
 - Kytke kaapelin kierretty suojavaippa maadoitusliittimeen.
 - Käytä erillistä PE-maadoituskaapelia (6a) tai kaapelia, jossa on erillinen PE-johdin (6b), jos vaipan johtavuus ei täytä PE-johtimelle asetettuja vaatimuksia. Jos PE-johdin on pienempi kuin 10 mm², on käytettävä lisäksi toista maadoitusjohdinta. Lisätietoja on laiteoppaassa.
 - Runkokoko R3: Kytke syöttökaapelin PE-lisäjohdin.
 - Kytke moottorikaapelin vaihejohtimet liittimiin T1/U, T2/V ja T3/W ja syöttökaapelin vaihejohtimet liittimiin L1, L2 ja L3.
7. Runkokoon R6 laitteet, jotka ovat suurempia kuin -040A-x: Leikkaa suojuksen läpät asennettuja kaapeleita varten. Runkokoko R8: Asenna sivulevyt, jos ne on irrotettu. Katso suojaan aukot syöttökaapeleita varten. Katso kuva [...F \(R6, R8\)...](#) sivulla [139](#).

8. Runkokoot R6 ja R8: Asenna syöttökaapelin liittimien suojus. Katso kuva [...F \(R6, R8\)...](#) sivulla 139.
9. Kiinnitä kaapelit mekaanisesti taajuusmuuttajan ulkopuolelle.

G – Kytke ohjauskaapelit

Toiminta:

1. Irrota etukansi (kannet), jos se on vielä paikallaan.
2. Runkokoko R3: Nosta ohjauspaneelin pidike ylös. Katso kuva [G \(R3\)...](#) sivulla 139.
3. Leikkaa kumitiivisteeseen sopivan kokoinen reikä ja liu'uta kumitiiviste kaapeliin. Vie kaapeli pohjalevyssä olevan reiän läpi ja kiinnitä tiiviste reikään.
4. Vedä kaapelit paikoilleen. Runkokoko R3: Katso kuva [...G \(R3\)...](#) sivulla 139. Runkokoko R6: Katso kuva [...G \(R6\)...](#) sivulla 139. Runkokoko R8: Katso kuva [...G \(R8\)...](#) sivulla 140.
5. Maadoita kaapelin ulompi suojavaippa 360 astetta maadoitusliittimen alta. Pidä kaapeli kuorimattomana niin lähelle ohjauskortin liittimiä kuin mahdollista.
6. Kiinnitä kaapelit mekaanisesti taajuusmuuttajan sisäpuolelle.
7. Runkokoko R3: Jätä parikaapelien suojavaipat ja maadoitusjohtimet kytkemättä taajuusmuuttajan päässä ja maadoita ne kaapelin toisessa päässä. Katkaise kytkemättömät johtimet taajuusmuuttajan päässä. Runkokoot R6 ja R8: Maadoita parikaapelien vaipat ja maadoitusjohdin ohjausyksikön alla olevaan kiinnikkeeseen.
8. Liitä johtimet asianmukaisesti ohjausyksikön liittimiin. Katso [Oletusarvoiset I/O-ohjauskytkennät](#) sivulla 52.
9. Kytke myös lisävarustemoduulit, mikäli niitä sisältyy toimitukseen. Lisätietoja on lisävarustemoduulin käyttöoppaassa ja asennusoppaassa.
10. Kiinnitä kaapelit mekaanisesti taajuusmuuttajan ulkopuolelle.

Huomaa:

- Jätä ohjauskaapelien suojavaippojen toiset päät kytkemättä.
- Pidä signaalijohtimien parikaapelit kierrettyinä mahdollisimman lähelle liittimiä.

H – Asenna kansi/kannet takaisin paikalleen

Katso kuvat [H \(R3, R6, R8\)...](#) sivulla 140.

■ Oletusarvoiset I/O-ohjauskytkennät

Johdinkoot:

0,5 ... 2,5 mm²

(24...14 AWG)

Kiristysmomentit:

0,5 Nm sekä yksilankaisille että kerrattuille johtimille.

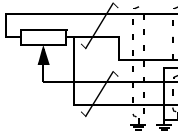

XPOW Ulkoinen syöttö

1	+24V	24 V DC, 2 A
2	GND	

XAI Ohjajännitte ja analogiatulot

1	+VREF	10 V DC, R_i 1...10 kohm
2	-VREF	-10 V DC, R_i 1...10 kohm
3	AGND	Maa
4	AI1+	Nopeusohje 0(2)...10 V, R_{in} > 200 kohm
5	AI1-	
6	AI2+	Tehdasasetus, ei ohjelmoitu.
7	AI2-	
J1	J1	AI1 virran/jännitteen valinnan siirtoliitin
J2	J2	AI2 virran/jännitteen valinnan siirtoliitin

XAO Analogialähdöt

1	AO1	Moottorin nopeus (rpm) 0...20 mA, R_L < 500 ohm
2	AGND	
3	AO2	Moottorin virta 0...20 mA, R_L < 500 ohm
4	AGND	

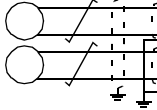

XD2D Taajuusmuuttajien välinen liitäntä

1	B	Taajuusmuuttajien välinen liitäntä
2	A	
3	BGND	
J3	J3	Liitännän päätevastuksen valintakytkin

XRO1, XRO2, XRO3 Relelähdöt

11	NC	Valmis 250 V AC / 30 V DC 2 A
12	COM	
13	NO	
21	NC	Käy 250 V AC / 30 V DC 2 A
22	COM	
23	NO	
31	NC	Vika(-1) 250 V AC / 30 V DC 2 A
32	COM	
33	NO	

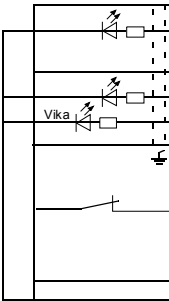

XD24 Digitaalinen lukitus

1	DIIL	Käyntilupa
2	+24VD	+24 V DC 200 mA
3	DICOM	Digitaalitulon maa
4	+24VD	+24 V DC 200 mA
5	DIOGND	Digitaalitulon/-lähdön maa
J6		Maadoituksen valintakytkin

XDIO Digitaalitulot/-lähdöt

1	DIO1	Lähtö: Valmis
2	DIO2	Lähtö: Käy

XDI Digitaalitulot

1	DI1	Seis (0) / Käyntiin (1)
2	DI2	Eteen (0) / Taakse (1)
3	DI3	Kuittaus
4	DI4	Kiihdytyksen ja hidastuksen valinta
5	DI5	Vakionopeus 1 (1 = Käytössä)
6	DI6	Tehdasasetus, ei ohjelmoitu.

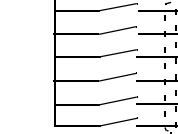

XSTO Safe torque off -toiminto

1	OUT1	Safe torque off. Molempien piirin on oltava suljettuina, jotta taajuusmuuttaja käynnistyy.
2	SGND	
3	IN1	
4	IN2	

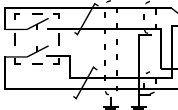

X12 Turvatoimintomodulin liitäntä

X13 Ohjauspaneelin liitäntä

X205 Muistyksikön liitäntä

Vaatimustenmukaisuusvakuutus (EU)

Power and productivity
for a better worldTM



EU Declaration of Conformity

Machinery Directive 2006/42/EC

We

Manufacturer: ABB Oy
Address: Hiomotie 13, 00380 Helsinki, Finland.
Phone: +358 10 22 11

declare under our sole responsibility that the following products:

Frequency converters

ACS880-01

ACS880-04/-04F

ACS880-M04

ACS880-11/-31/-14/-34

with regard to the built-in safety function:

Safe torque off;

and with regard to the following optional safety functions with FSO-12 module (option code +Q973, encoderless):

Safe stop 1; Safe stop emergency; Safely-limited speed; Safe maximum speed; Safe brake control; Prevention of Unexpected Start-up;

and with regard to the following optional safety functions (option codes +Q972 and +L521, encoder supported):

Safe stop 1; Safe stop emergency; Safely-limited speed; Safe maximum speed; Safe brake control; Safe speed monitor; Safe direction; Prevention of Unexpected Start-up;

and with regard to the following optional safety function with FPTC-01 thermistor protection module (option code +L536):

Safe Motor Temperature;

are in conformity with all the relevant safety component requirements of EU Machinery Directive 2006/42/EC, when the listed safety functions are used for safety component functionality.

Power and productivity
for a better world™



EU Declaration of Conformity

Machinery Directive 2006/42/EC

The following harmonized standards have been applied:

EN 61800-5-2:2007	<i>Adjustable speed electrical power drive systems – Part 5-2: Safety requirements - Functional</i>
EN 62061:2005 + AC:2010 + A1:2013 + A2:2015	<i>Safety of machinery – Functional safety of safety-related electrical, electronic and programmable electronic control systems</i>
EN ISO 13849-1:2015	<i>Safety of machinery – Safety-related parts of control systems. Part 1: General requirements</i>
EN ISO 13849-2:2012	<i>Safety of machinery – Safety-related parts of the control systems. Part 2: Validation</i>
EN 60204-1: 2006 + A1:2009 + AC:2010	<i>Safety of machinery – Electrical equipment of machines – Part 1: General requirements</i>

The following other standards have been applied:

IEC 61508:2010	<i>Functional safety of electrical / electronic / programmable electronic safety-related systems</i>
IEC 61800-5-2:2016	<i>Adjustable speed electrical power drive systems – Part 5-2: Safety requirements - Functional</i>

The products referred in this Declaration of conformity fulfil the relevant provisions of other European Union Directives which are notified in Single EU Declaration of conformity 3AXD10000497831.

FI

Person authorized to compile the technical file:

Name and address: Juha Martinmaa, Hiomotie 13, 00380 Helsinki, Finland.

Helsinki, 15 Sep 2017

Manufacturer representative:

Vesa Kandell
Vice President, ABB Oy

FR – Guide d'installation

Ce guide vous explique brièvement comment installer le variateur. Pour une présentation détaillée de l'installation, consultez le *Manuel d'installation des variateurs ACS880-31* (3AXD50000315666). Cf. *Guide de mise en route pour l'ACS880 avec programme de contrôle standard* (3AUA0000098062).

Pour consulter un manuel, rendez-vous à l'adresse www.abb.com/drives/documents et recherchez le numéro du document souhaité.

Consignes de sécurité



ATTENTION ! Vous devez suivre les consignes de sécurité à la lettre. Leur non-respect est susceptible de provoquer des blessures graves, voire mortelles, ou des dégâts matériels.

- Seuls des électriciens qualifiés sont autorisés à procéder à l'installation et la maintenance du variateur.
 - N'intervenez jamais sur le variateur, le moteur ou son câblage sous tension. S'il est déjà raccordé au réseau, vous devez attendre 5 minutes après sectionnement de l'alimentation avant d'intervenir.
 - Vous ne devez jamais intervenir sur les câbles de commande lorsque le variateur ou les circuits de commande externes sont sous tension.
 - Vous ne devez pas alimenter le variateur avec une tension supérieure à la valeur figurant sur sa plaque signalétique.
 - Le variateur ainsi que le moteur et les équipements annexes doivent être mis à la terre en permanence via le bus PE de l'alimentation.
 - Tailles R6 et R8 : Le module variateur est lourd et son centre de gravité est élevé. Utilisez un dispositif de levage. Vous ne devez pas pencher le variateur. Vous risquez de vous blesser en soulevant le module variateur manuellement ou s'il bascule et se renverse. Assurez-vous que la paroi et le dispositif de fixation supportent le poids de l'appareil.
 - En cas de perçage ou de rectification d'un élément, évitez toute pénétration de poussière dans le variateur.
 - Assurez-vous que le sol sous le variateur ainsi que la paroi de fixation sont en matériau ininflammable.
-

Vérification des condensateurs

Si le variateur est resté plus de trois ans sans être mis sous tension (en stockage ou non utilisé), vous devez réactiver les condensateurs.

Pour connaître la date de fabrication, consultez le numéro de série, qui se trouve sur la plaque signalétique de l'appareil. Le numéro de série est au format MAASSRXXXX, avec AA et SS indiquant respectivement l'année et la semaine de fabrication :

AA : 17, 18, 19, ... = 2017, 2018, 2019, etc.

SS : 01, 02, 03, ... = semaine 1, semaine 2, semaine 3, ...

Pour la procédure de réactivation, cf. document anglais *Converter module capacitor reforming instructions* (3BFE64059629), disponible sur Internet à l'adresse www.abb.com/drives/documents.

Données

Valeurs nominales selon CEI

ACS880-31	Câble (mm ²)	Fusible aR	Pertes (W)
U_N triphasée = 400 V (380...415 V)			
09A4-3	3×1,5	170M1561	226
12A6-3	3×1,5	170M1561	329
017A-3	3×6	170M1563	395
025A-3	3×6	170M1563	579
032A-3	3×10	170M1565	625
038A-3	3×10	170M1565	751
045A-3	3×16	170M1566	912
061A-3	3×25	170M1567	1088
072A-3	3×35	170M1568	1502
087A-3	3×50	170M1569	1904
105A-3	3×50	170M3817	1877
145A-3	3×95	170M3817	2963
169A-3	3×120	170M5809	3168
206A-3	3×150	170M5810	3990
U_N triphasée = 500 V (380...500 V)			
07A6-5	3×1,5	170M1561	219
11A0-5	3×1,5	170M1561	278
014A-5	3×6	170M1563	321
021A-5	3×6	170M1563	473
027A-5	3×10	170M1565	625
034A-5	3×10	170M1565	711
040A-5	3×16	170M1566	807
052A-5	3×25	170M1567	960
065A-5	3×35	170M1568	1223
077A-5	3×35	170M1569	1560
101A-5	3×50	170M3816	1995
124A-5	3×95	170M3817	2800
156A-5	3×120	170M5808	3168
180A-5	3×150	170M5810	3872

3AXD0000588487

Sélection des câbles de puissance

Reportez-vous à la section *Données* page 56.

Refroidissement

Reportez-vous à la section [Données](#) page 56. Condensation ou givre interdits. Sans déclassement, la plage de température de fonctionnement admissible va de -15 à +40 °C.

Protection du variateur et du câble réseau

Cf. [Données](#) page 56.

A – Montage mural du variateur

Cf. figure [A](#) page 137.

B – Dépose du capot

Retirez le ou les capot(s). Cf. figures [B \(R3\)](#) et [B \(R6, R8\)](#)... page 137.

C – Vérification de la compatibilité avec les réseaux en régime IT (neutre isolé ou impédant) ou en mise à la terre asymétrique

Cf. figure [C](#) page 137.

FR



ATTENTION ! Si le variateur est destiné à être raccordé sur un réseau en régime IT (neutre isolé ou impédant) ou en mise à la terre asymétrique, vous devez retirer le filtre RFI (option +E202) et la varistance phase-terre. Cf. manuel d'installation du variateur.

D – Mesure de la résistance d'isolement des câbles de puissance et du moteur

Raccordez le câble moteur côté moteur. Pour minimiser les perturbations HF, effectuez une reprise de masse sur 360° du blindage du câble moteur en entrée de la boîte à bornes du moteur. Cf. figure [D](#) page 137.

Mesurez la résistance d'isolement du moteur et de son câblage. Cf. figure [D](#) page 137. **Nota :** La présence d'humidité à l'intérieur de l'enveloppe du moteur réduit sa résistance d'isolement. Si vous craignez que le moteur soit humide, séchez-le et reprenez les mesures.

Mesurez la résistance d'isolement du câble d'alimentation avant de le raccorder au variateur. Respectez la réglementation locale.

E – Fixation des étiquettes de mise en garde dans votre langue

Cf. figure [E](#) page [138](#).

F – Raccordement des câbles de puissance

Utilisez un câble moteur symétrique blindé. Si le blindage du câble constitue le seul conducteur PE, vérifiez que sa conductivité est suffisante pour assurer la protection.

Note pour la taille R3 : Vous devez avoir un conducteur PE supplémentaire dans le câble d'alimentation. Cf. manuel d'installation pour des détails supplémentaires.

Procédure :

1. Taille R6 et R8 : Retirez la protection des bornes de puissance. Cf. figure [F \(R6, R8\)](#)... page [138](#) Taille R8 : Retirez les platines latérales pour une installation plus facile.
2. Sur la tôle de fond, retirez les passe-câbles en caoutchouc des câbles à raccorder. Cf. figure [...F...](#) page [138](#)
3. Découpez un trou de diamètre adéquat dans les passe-câbles en caoutchouc. Enfilez les passe-câbles sur les câbles.

4. Préparez les extrémités des câbles. Cf. figure [...F...](#) page [138](#)

Vous devrez effectuer une reprise de masse sur 360° du blindage nu. Marquez la queue de cochon du blindage en jaune et vert pour indiquer qu'il s'agit du conducteur PE.

Sont présentées deux configurations symétriques à trois conducteurs ainsi qu'une configuration à quatre conducteurs, réservée au câblage de l'alimentation.

Si vos câbles sont en aluminium, graissez les brins d'aluminium dénudés avant de les raccorder au variateur.

5. Insérez les câbles dans les trous de la platine d'entrée des câbles et fixez-y les passe-câbles.
6. Raccordez les câbles en serrant aux couples indiqués sur le schéma. Cf. figures [...F...](#) page [138](#) et [139](#):
 - Effectuez une reprise de masse sur 360° du blindage en serrant le collier de la platine de mise à la terre du câble de puissance sur la partie dénudée du câble.
 - Raccordez le blindage torsadé du câble à la borne de terre.
 - Utilisez un câble de terre PE séparé (6a) ou un câble avec un conducteur PE séparé (6b) si la conductivité du blindage ne satisfait pas aux exigences pour le conducteur PE. Si la section du conducteur PE est inférieure à 10 mm², vous devez utiliser un deuxième conducteur de terre. Cf. manuel d'installation pour des détails supplémentaires.

- Taille R3 : Raccordez le conducteur PE supplémentaire du câble d'alimentation.
 - Connectez les conducteurs de phase du câble moteur aux bornes T1/U, T2/V et T3/W, et les conducteurs de phase du câble d'alimentation aux bornes L1, L2 et L3.
7. Taille R6 au-delà du type -040A-x : Dans les protections, découpez les pattes pour le passage des câbles. Taille R8 : Remettez les tôles latérales si vous les aviez retirées. Percez les ouvertures dans la protection pour les câbles d'alimentation. Cf. figure *...F (R6, R8)...* page 139
 8. Tailles R6 et R8 : Placez la protection sur les bornes de puissance. Cf. figure *...F (R6, R8)...* page 139
 9. Fixez mécaniquement les câbles à l'extérieur du variateur.

G – Raccordement des câbles de commande

Procédure :

1. Si ce n'est pas déjà le cas, déposez le capot avant.
2. Taille R3 : Soulevez le logement de la micro-console. Cf. figure *G (R3)...* page 139
3. Découpez un trou de diamètre adéquat dans le passe-câbles en caoutchouc pour le glisser sur le câble. Insérez le câble dans le trou de la plaque inférieure et fixez-y le passe-câbles.
4. Posez les câbles. Taille R3 : Cf. figure *...G (R3)...* page 139
Taille R6 : Cf. figure *...G (R6)...* page 139 Taille R8 : Cf. figure *...G (R8)...* page 140
5. Effectuez une reprise de masse sur 360° du blindage externe sous le collier de terre. Le câble ne doit pas être dénudé et doit cheminer aussi près que possible des bornes de la carte de commande.
6. Fixez mécaniquement les câbles à l'intérieur du variateur.
7. Taille R3 : Laissez les blindages doubles et mises à la terre des câbles non raccordés côté variateur et mettez-les à la terre à l'autre extrémité. Coupez tout fil non raccordé côté variateur. Taille R6 et R8 : Mettez à la terre les blindages doubles et les fils de terre au niveau du collier situé sous l'unité de commande.
8. Raccordez les conducteurs aux bornes correspondantes de l'unité de commande. Cf. *Schéma de raccordement des signaux d'E/S (préréglages)* page 61.
9. Raccordez les modules optionnels, si inclus à la livraison. Reportez-vous au guide d'installation ou au manuel de l'utilisateur du module.
10. Fixez mécaniquement les câbles à l'extérieur du variateur.

Nota :

- Laissez les autres extrémités du blindage du câble non raccordées.
- Les paires de fils doivent rester torsadées aussi près que possible des bornes.

H – Remise du ou des capot(s) en place

Cf. figures [H \(R3, R6, R8\)](#)... page [140](#)

■ Schéma de raccordement des signaux d'E/S (préréglages)

Section des fils :
0,5 ... 2,5 mm²
(24...14 AWG)
Couples de serrage : 0,5
N·m (0,4 lbf·ft)
pour câbles à
brins multiples
toronnés et
monobrin.

XPOW		Entrée alimentation externe	
1	+24VI	24 Vc.c., 2 A	
2	GND		
XAI		Tension de référence et entrées analogiques	
1	+VREF	10 Vc.c., R_1 1...10 kohm	
2	-VREF	-10 Vc.c., R_1 1...10 kohm	
3	AGND	Terre	
4	AI1+	Référence vitesse 0(2)...10 V, $R_{en} >$	
5	AI1-	200 kohm	
6	AI2+	Non utilisée par défaut 0(4)...20 mA, R_{en}	
7	AI2-	= 100 ohm	
J1	J1	Sélection courant/tension AI1 par cavalier	
J2	J2	Sélection courant/tension AI2 par cavalier	
XAO		Sorties analogiques	
1	AO1	Vitesse moteur tr/min 0...20mA, $R_L <$	
2	AGND	500 ohm	
3	AO2	Courant moteur 0...20 mA, $R_L <$	
4	AGND	500 ohm	
XD2D		Liaison multivariateurs (D2D)	
1	B		
2	A	Liaison multivariateurs	
3	BGND		
J3	J3	Commutateur de terminaison de la liaison D2D	
XRO1, XRO2, XRO3		Sorties relais	
11	NC	Prêt	
12	COM	250 Vc.a. / 30 Vc.c.	
13	NO	2 A	
21	NC	En marche	
22	COM	250 Vc.a. / 30 Vc.c.	
23	NO	2 A	
31	NC	Défaut(-1)	
32	COM	250 Vc.a. / 30 Vc.c.	
33	NO	2 A	
XD24		Verrouillage logique	
1	DIIL	Validation Marche	
2	+24VD	+24 Vc.c. 200 mA	
3	DICOM	Masse entrées logiques	
4	+24VD	+24 Vc.c. 200 mA	
5	DIOGND	Masse entrées/sorties logiques	
J6		Commutateur de sélection de masse	
XDIO		Entrées/sorties logiques	
1	DIO1	Sortie : Prêt	
2	DIO2	Sortie : En marche	
XDI		Entrées logiques	
1	DI1	Arrêt (0) / Démarrage (1)	
2	DI2	Avant (0) / Arrière (1)	
3	DI3	Réarmement	
4	DI4	Sélection accélération & décélération	
5	DI5	Vitesse constante 1 (1 = On)	
6	DI6	Non utilisée par défaut	
XSTO		Interruption sécurisée du couple STO	
1	OUT1		
2	SGND		
3	IN1		
4	IN2		
			Interruption sécurisée du couple. Les deux circuits doivent être fermés pour autoriser le démarrage du variateur.
X12		Raccordement module de fonctions de sécurité	
X13		Raccordement micro-console	
X205		Raccordement unité mémoire	

Certificat d'incorporation (UE)

Power and productivity
for a better world™



EU Declaration of Conformity

Machinery Directive 2006/42/EC

We

Manufacturer: ABB Oy
Address: Hiomotie 13, 00380 Helsinki, Finland.
Phone: +358 10 22 11

declare under our sole responsibility that the following products:

Frequency converters

ACS880-01

ACS880-04/-04F

ACS880-M04

ACS880-11/-31/-14/-34

with regard to the built-in safety function:

Safe torque off;

and with regard to the following optional safety functions with FSO-12 module (option code +Q973, encoderless):

Safe stop 1; Safe stop emergency; Safely-limited speed; Safe maximum speed; Safe brake control; Prevention of Unexpected Start-up;

and with regard to the following optional safety functions (option codes +Q972 and +L521, encoder supported):

Safe stop 1; Safe stop emergency; Safely-limited speed; Safe maximum speed; Safe brake control; Safe speed monitor; Safe direction; Prevention of Unexpected Start-up;

and with regard to the following optional safety function with FPTC-01 thermistor protection module (option code +L536):

Safe Motor Temperature;

are in conformity with all the relevant safety component requirements of EU Machinery Directive 2006/42/EC, when the listed safety functions are used for safety component functionality.

Power and productivity
for a better world™



EU Declaration of Conformity

Machinery Directive 2006/42/EC

The following harmonized standards have been applied:

EN 61800-5-2:2007	<i>Adjustable speed electrical power drive systems – Part 5-2: Safety requirements - Functional</i>
EN 62061:2005 + AC:2010 + A1:2013 + A2:2015	<i>Safety of machinery – Functional safety of safety-related electrical, electronic and programmable electronic control systems</i>
EN ISO 13849-1:2015	<i>Safety of machinery – Safety-related parts of control systems. Part 1: General requirements</i>
EN ISO 13849-2:2012	<i>Safety of machinery – Safety-related parts of the control systems. Part 2: Validation</i>
EN 60204-1: 2006 + A1:2009 + AC:2010	<i>Safety of machinery – Electrical equipment of machines – Part 1: General requirements</i>

The following other standards have been applied:

IEC 61508:2010	Functional safety of electrical / electronic / programmable electronic safety-related systems
IEC 61800-5-2:2016	Adjustable speed electrical power drive systems – Part 5-2: Safety requirements - Functional

The products referred in this Declaration of conformity fulfil the relevant provisions of other European Union Directives which are notified in Single EU Declaration of conformity 3AXD10000497831.

Person authorized to compile the technical file:

Name and address: Juha Martinmaa, Hiomotie 13, 00380 Helsinki, Finland.

Helsinki, 15 Sep 2017

Manufacturer representative:

Vesa Kandell
Vice President, ABB Oy

IT – Guida rapida all'installazione

Questa guida descrive brevemente la procedura di installazione del convertitore di frequenza. Per le informazioni complete sull'installazione, vedere *ACS880-31 Drives Hardware Manual* (3AXD50000045933 [inglese]). Per le istruzioni di avviamento, vedere *ACS880 Drives with Primary Control Program Quick Start-up Guide* (3AUA0000098062 [inglese]).

Per consultare i manuali, visitare www.abb.com/drives/documents e cercare il numero di documento.

Rispettare le norme di sicurezza



AVVERTENZA! Rispettare le seguenti norme di sicurezza. La mancata osservanza di queste norme può mettere in pericolo l'incolumità delle persone, con rischio di morte, e danneggiare le apparecchiature:

- L'installazione e la manutenzione del convertitore di frequenza devono essere eseguite solo da elettricisti qualificati.
- Non operare mai sul convertitore, sul cavo motore o sul motore quando è inserita l'alimentazione. Se il convertitore è già collegato all'alimentazione, disinserirla e attendere 5 minuti.
- Non lavorare mai sui cavi di controllo quando il convertitore o i circuiti di controllo esterni sono alimentati.
- Non collegare il convertitore a una tensione superiore al valore indicato sull'etichetta di identificazione dell'unità.
- Mettere sempre a terra il convertitore, il motore e le apparecchiature adiacenti collegandoli al bus di terra (PE) dell'alimentazione.
- Telai R6 e R8: il modulo convertitore è pesante e ha il baricentro alto. Utilizzare un dispositivo di sollevamento per sollevarlo. Non inclinare il convertitore. Il sollevamento manuale, o il ribaltamento dell'unità per un'eccessiva inclinazione, possono causare infortuni. Assicurarsi che la parete e i dispositivi di fissaggio siano in grado di sostenere il peso.
- Fare attenzione che i detriti provocati dall'esecuzione di fori non si infiltrino nell'unità.
- Assicurarsi che il pavimento sotto il convertitore e la parete dove è installato il convertitore siano non infiammabili.

Ricondizionamento dei condensatori

Se il convertitore è fermo da oltre tre anni (perché è rimasto inutilizzato oppure in magazzino), è necessario ricondizionare i condensatori.

La data di fabbricazione si legge dal numero di serie riportato sull'etichetta identificativa del convertitore. Il formato del numero di serie è MYYWWRXXXX. YY e WW indicano rispettivamente l'anno e la settimana di produzione, nel modo seguente:

YY: 17, 18, 19, ... per 2017, 2018, 2019, ...

WW: 01, 02, 03, ... per settimana 1, settimana 2, settimana 3, ...

Per informazioni sul ricondizionamento dei condensatori, vedere *Converter Module Capacitor Reforming Instructions* (3BFE64059629 [inglese]), disponibile in Internet al sito www.abb.com/drives/documents.

Dati

Valori nominali IEC

ACS880-31	Cavo (mm ²)	Fusibile aR	Perdite (W)
Trifase $U_N = 400\text{ V}$ (380...415 V)			
09A4-3	3×1.5	170M1561	226
12A6-3	3×1.5	170M1561	329
017A-3	3×6	170M1563	395
025A-3	3×6	170M1563	579
032A-3	3×10	170M1565	625
038A-3	3×10	170M1565	751
045A-3	3×16	170M1566	912
061A-3	3×25	170M1567	1088
072A-3	3×35	170M1568	1502
087A-3	3×50	170M1569	1904
105A-3	3×50	170M3817	1877
145A-3	3×95	170M3817	2963
169A-3	3×120	170M5809	3168
206A-3	3×150	170M5810	3990
Trifase $U_N = 500\text{ V}$ (380...500 V)			
07A6-5	3×1.5	170M1561	219
11A0-5	3×1.5	170M1561	278
014A-5	3×6	170M1563	321
021A-5	3×6	170M1563	473
027A-5	3×10	170M1565	625
034A-5	3×10	170M1565	711
040A-5	3×16	170M1566	807
052A-5	3×25	170M1567	960
065A-5	3×35	170M1568	1223
077A-5	3×35	170M1569	1560
101A-5	3×50	170M3816	1995
124A-5	3×95	170M3817	2800
156A-5	3×120	170M5808	3168
180A-5	3×150	170M5810	3872

3AXD00000588487

Selezione dei cavi di potenza

Vedere [Dati](#) a pag. 66.

Raffreddamento

Vedere *Dati* a pag. 66. Non sono ammessi ghiaccio e condensa. Il range di temperatura operativa del convertitore, senza declassamento, è -15 ... +40 °C.

Protezione del convertitore e del cavo di alimentazione di ingresso

Vedere *Dati* a pag. 66.

A – Montaggio del convertitore di frequenza a parete

Vedere la figura *A* a pag. 137.

B – Rimozione del coperchio

Rimuovere il coperchio (o i coperchi). Vedere le figure *B (R3)* e *B (R6, R8)*... a pag. 137.

C – Verifica della compatibilità con sistemi IT (senza messa a terra) e sistemi a triangolo con una fase a terra

Vedere la figura *C* a pag. 137.



AVVERTENZA! Se il convertitore di frequenza sarà collegato a un sistema IT (senza messa a terra o con messa a terra ad alta resistenza) o a un sistema a triangolo con una fase a terra, scollegare il filtro EMC (opzione +E202) e il varistore fase-terra. Vedere il Manuale hardware del convertitore.

IT

D – Controllo dell'isolamento dei cavi di potenza e del cavo motore

Collegare il cavo motore sul lato motore. Per ridurre al minimo le interferenze da radiofrequenza, mettere a terra la schermatura del cavo motore a 360° in corrispondenza dell'ingresso cavi della morsettiera del motore. Vedere la figura *D* a pag. 137.

Controllare l'isolamento del motore e del cavo motore. Vedere la figura *D* a pag. 137.

Nota: la presenza di umidità all'interno dell'alloggiamento del motore riduce la resistenza di isolamento. In caso di umidità, asciugare il motore e ripetere la misurazione.

Verificare l'isolamento del cavo di ingresso prima di collegarlo al convertitore di frequenza. Attenersi alle normative locali.

E – Applicazione degli adesivi di avvertenza nelle lingue

locali

Vedere la figura [E](#) a pag. [138](#).

F – Collegamento dei cavi di alimentazione

Utilizzare un cavo schermato di tipo simmetrico per il motore. Se la schermatura del cavo è l'unico conduttore PE, assicurarsi che abbia una sezione adeguata per il circuito di terra.

Nota per telaio R3: accertarsi di avere un conduttore PE supplementare nei cavi della potenza di ingresso. Vedere il Manuale hardware per ulteriori informazioni.

Procedura:

1. Telai R6 e R8: rimuovere la protezione sui morsetti dei cavi di potenza. Vedere la figura [F \(R6, R8\)](#)... a pag. [138](#). Telaio R8: per semplificare l'installazione, rimuovere le piastre laterali.
2. Rimuovere i gommini dalla piastra inferiore per il passaggio dei cavi che si intendono collegare. Vedere la figura [...F...](#) a pag. [138](#).
3. Tagliare un foro di dimensioni adeguate nei gommini. Infilare i gommini sui cavi.
4. Preparare le estremità dei cavi. Vedere la figura [...F...](#) a pag. [138](#).

La schermatura dovrà essere messa a terra a 360°. Contrassegnare la treccia ottenuta con la schermatura come conduttore PE con i colori giallo e verde.

La figura mostra due opzioni alternative di cavi simmetrici a tre conduttori e un cavo a quattro conduttori. Il cavo a quattro conduttori deve essere utilizzato solo per la potenza di ingresso.

Se si utilizzano cavi in alluminio, cospargere di grasso le porzioni spellate del cavo prima di collegare quest'ultimo al convertitore di frequenza.

5. Inserire i cavi nei fori della piastra di ingresso e fissare i gommini ai fori.
6. Collegare i cavi (applicare le coppie indicate nella figura). Vedere le figure [...F...](#) a pag. [138](#) e [139](#):
 - Mettere a terra la schermatura a 360° serrando il morsetto della piastra di messa a terra del cavo di potenza sulla parte spellata del cavo.
 - Collegare la schermatura intrecciata del cavo al morsetto di terra.
 - Utilizzare un cavo PE di messa a terra separato (6a) o un cavo con conduttore PE separato (6b) se la conduttività della schermatura non è conforme ai requisiti previsti per il conduttore PE. Se il conduttore PE è inferiore a 10 mm², è necessario utilizzare un secondo conduttore di protezione di terra. Vedere il Manuale hardware per ulteriori informazioni.
 - Telaio R3: collegare il conduttore PE supplementare dei cavi della potenza di ingresso.
 - Collegare i conduttori di fase del cavo motore ai morsetti T1/U, T2/V e T3/W, e i conduttori di fase del cavo di ingresso ai morsetti L1, L2 e L3.

7. Telai R6 superiori a -040A-x: tagliare le linguette nella protezione per i cavi installati. Telaio R8: installare le piastre laterali, se erano state rimosse. Aprire dei fori nella protezione per i cavi di ingresso. Vedere la figura [...F \(R6, R8\)...](#) a pag. [139](#).
8. Telai R6 e R8: installare la protezione sui morsetti dei cavi di potenza. Vedere la figura [...F \(R6, R8\)...](#) a pag. [139](#).
9. Fissare meccanicamente i cavi all'esterno del convertitore di frequenza.

G – Collegamento dei cavi di controllo

Procedura:

1. Rimuovere il coperchio o i coperchi anteriori, se non sono già stati rimossi.
2. Telaio R3: sollevare il supporto del pannello di controllo. Vedere la figura [G \(R3\)...](#) a pag. [139](#).
3. Praticare un foro di dimensioni idonee nel gommino e fare scivolare il gommino sul cavo. Far passare il cavo attraverso un foro della piastra inferiore e inserire il gommino nel foro.
4. Posare i cavi. Telaio R3: vedere la figura [...G \(R3\)...](#) a pag. [139](#). Telaio R6: vedere la figura [...G \(R6\)...](#) a pag. [139](#). Telaio R8: vedere la figura [...G \(R8\)...](#) a pag. [140](#).
5. Mettere a terra la schermatura esterna del cavo a 360° sotto il morsetto di terra. Il cavo non spellato deve rimanere il più possibile vicino ai morsetti della scheda di controllo.
6. Fissare meccanicamente i cavi all'interno del convertitore di frequenza.
7. Telaio R3: lasciare scollegati le schermature dei doppini e i fili di terra sul lato del convertitore, e metterli a terra sull'altro lato. Tagliare tutti i fili scollegati sul lato del convertitore. Telai R6 e R8: mettere a terra le schermature dei doppini e il filo di terra in corrispondenza del morsetto sotto l'unità di controllo.
8. Collegare i conduttori ai corrispondenti morsetti dell'unità di controllo. Vedere [Schema di collegamento degli I/O di default](#) a pag. [70](#).
9. Collegare i moduli opzionali, se inclusi nella fornitura. Vedere il Manuale utente o la Guida di installazione dei moduli opzionali.
10. Fissare meccanicamente i cavi all'esterno del convertitore di frequenza.

Nota:

- lasciare scollegate le altre estremità delle schermature dei cavi di controllo.
- Tenere i doppini dei fili dei segnali intrecciati il più possibile vicino ai morsetti.

H – Reinstallazione del coperchio (o dei coperchi)

Vedere le figure [H \(R3, R6, R8\)...](#) a pag. [140](#).

■ Schema di collegamento degli I/O di default

Dimensioni fili:
0.5 ... 2.5 mm²

(24 ... 14 AWG)

Coppie di serraggio:
0.5 N·m
(0.4 lbf·ft) per
cavi intrecciati
e pieni.

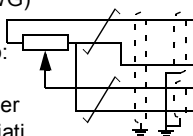

XPO Ingresso alimentazione esterna

1	+24VI	24 Vcc, 2 A
2	GND	

XAI Ingressi analogici e tensione di riferimento

1	+VREF	10 Vcc, R_i 1...10 kohm
2	-VREF	-10 Vcc, R_i 1...10 kohm
3	AGND	Terra
4	AI1+	Riferimento velocità 0(2)...10 V, $R_{in} > 200$ kohm
5	AI1-	
6	AI2+	Di default non utilizzati. 0(4)...20 mA, $R_{in} = 100$ ohm
7	AI2-	
J1	J1	Ponticello di selezione corrente/tensione AI1
J2	J2	Ponticello di selezione corrente/tensione AI2

XAO Uscite analogiche

1	AO1	Velocità motore rpm 0...20 mA, $R_L < 500$ ohm
2	AGND	
3	AO2	Corrente motore 0...20 mA, $R_L < 500$ ohm
4	AGND	

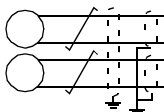

XD2D Collegamento drive-to-drive

1	B	Collegamento drive-to-drive
2	A	
3	BGND	
J3	J3	Interruttore terminazione collegamento drive-to-drive

XRO1, XRO2, XRO3 Uscite relè

11	NC	Pronto 250 Vca / 30 Vcc 2 A
12	COM	
13	NO	
21	NC	In marcia 250 Vca / 30 Vcc 2 A
22	COM	
23	NO	
31	NC	Guasto(-1) 250 Vca / 30 Vcc 2 A
32	COM	
33	NO	

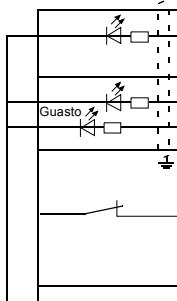

XD24 Interblocco digitale

1	DIIL	Abilitazione marcia
2	+24VD	+24 Vcc 200 mA
3	DICOM	Terra ingressi digitali
4	+24VD	+24 Vcc 200 mA
5	DIOGND	Terra ingressi/uscite digitali
J6	J6	Interruttore di selezione terra

XDIO Ingressi/uscite digitali

1	DIO1	Uscita: pronto
2	DIO2	Uscita: in marcia

XDI Ingressi digitali

1	DI1	Arresto (0) / Avviamento (1)
2	DI2	Avanti (0) / Indietro (1)
3	DI3	Reset
4	DI4	Selezione accelerazione e decelerazione
5	DI5	Velocità costante 1 (1 = On)
6	DI6	Di default non utilizzato.

XST Safe Torque Off

1	OUT1	Safe Torque Off. Per avviare il convertitore entrambi i circuiti devono essere chiusi.
2	SGND	
3	IN1	
4	IN2	

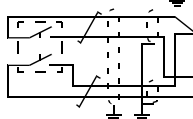

X12 Collegamento modulo funzioni di sicurezza

X13 Collegamento pannello di controllo

X205 Collegamento unità di memoria

Dichiarazione di conformità (EU)

Power and productivity
for a better world™



EU Declaration of Conformity

Machinery Directive 2006/42/EC

We

Manufacturer: ABB Oy
Address: Hiomotie 13, 00380 Helsinki, Finland.
Phone: +358 10 22 11

declare under our sole responsibility that the following products:

Frequency converters

ACS880-01

ACS880-04/-04F

ACS880-M04

ACS880-11/-31/-14/-34

with regard to the built-in safety function:

Safe torque off;

and with regard to the following optional safety functions with FSO-12 module (option code +Q973, encoderless):

Safe stop 1; Safe stop emergency; Safely-limited speed; Safe maximum speed; Safe brake control; Prevention of Unexpected Start-up;

and with regard to the following optional safety functions (option codes +Q972 and +L521, encoder supported):

Safe stop 1; Safe stop emergency; Safely-limited speed; Safe maximum speed; Safe brake control; Safe speed monitor; Safe direction; Prevention of Unexpected Start-up;

and with regard to the following optional safety function with FPTC-01 thermistor protection module (option code +L536):

Safe Motor Temperature;

are in conformity with all the relevant safety component requirements of EU Machinery Directive 2006/42/EC, when the listed safety functions are used for safety component functionality.



EU Declaration of Conformity

Machinery Directive 2006/42/EC

The following harmonized standards have been applied:

EN 61800-5-2:2007	<i>Adjustable speed electrical power drive systems – Part 5-2: Safety requirements - Functional</i>
EN 62061:2005 + AC:2010 + A1:2013 + A2:2015	<i>Safety of machinery – Functional safety of safety-related electrical, electronic and programmable electronic control systems</i>
EN ISO 13849-1:2015	<i>Safety of machinery – Safety-related parts of control systems. Part 1: General requirements</i>
EN ISO 13849-2:2012	<i>Safety of machinery – Safety-related parts of the control systems. Part 2: Validation</i>
EN 60204-1: 2006 + A1:2009 + AC:2010	<i>Safety of machinery – Electrical equipment of machines – Part 1: General requirements</i>

The following other standards have been applied:

IEC 61508:2010	<i>Functional safety of electrical / electronic / programmable electronic safety-related systems</i>
IEC 61800-5-2:2016	<i>Adjustable speed electrical power drive systems – Part 5-2: Safety requirements - Functional</i>

The products referred in this Declaration of conformity fulfil the relevant provisions of other European Union Directives which are notified in Single EU Declaration of conformity 3AXD10000497831.

Person authorized to compile the technical file:

Name and address: Juha Martinmaa, Hiomotie 13, 00380 Helsinki, Finland.

Helsinki, 15 Sep 2017

Manufacturer representative:

Vesa Kandell
Vice President, ABB Oy

NL – Beknopte installatiegids

Deze gids geeft een beknopte beschrijving van het installeren van de omvormer. Zie voor volledige informatie over installatie *ACS880-31 drives hardware manual* (3AXD50000045933 [Engels]). Zie voor opstart-instructies *ACS880 drives with primary control program quick start-up guide* (3AUA0000098062 [Engels]).

Om een handleiding te lezen gaat u naar www.abb.com/drives/documents en zoekt u het documentnummer.

Volg de veiligheidsvoorschriften



WAARSCHUWING! Volg deze instructies. Indien u deze negeert, kan dit lichamelijk letsel of de dood tot gevolg hebben, of er kan schade aan de apparatuur ontstaan:

- De installatie en het onderhoud van de omvormer mag uitsluitend worden uitgevoerd door gekwalificeerde elektrotechnische vakmensen.
- Voer nooit werkzaamheden uit aan de frequentie-omvormer, de motorkabel of de motor als ze onder spanning staan. Als de omvormer al is aangesloten op het voedingsnet, ontkoppelt u de omvormer en wacht u 5 minuten.
- Voer nooit werkzaamheden uit aan de besturingskabels als de omvormer of externe besturingscircuits onder spanning staan.
- Sluit de omvormer niet op een spanning aan die hoger is dan die vermeld is op het typeplaatje.
- Aard de omvormer, de motor en bijbehorende apparatuur altijd aan de veiligheidsaarde (PE) -bus van de voeding.
- **Frames R6 en R8:** De omvormermodule is zwaar en het zwaartepunt ligt hoog. Gebruik een hijsstoestel om te tillen. Kantel de omvormer niet. Handmatig optillen, of omvallen vanwege kantelen, kan lichamelijk letsel veroorzaken. Zorg er voor dat de wand en de bevestigingsmaterialen het gewicht kunnen dragen.
- Zorg dat er geen boor-, snij- of slijpafval in de omvormer binnendringt.
- Zorg er voor dat de vloer onder de omvormer en de wand waaraan de omvormer is gemonteerd onbrandbaar zijn.

NL

Controleer of condensatoren opnieuw gevormed moeten worden

Als de omvormer langer dan drie jaar niet ingeschakeld is (ofwel in opslag of ongebruikt), moet u de condensatoren opnieuw formeren.

U kunt de fabricagedatum bepalen uit het serienummer, dat op het typeplaatje, bevestigd aan de omvormer, te vinden is. Het serienummer heeft het formaat MYYWWRXXXX. YY en WW bepalen als volgt het jaar en de week van fabricage:

YY: 17, 18, 19, ... voor 2017, 2018, 2019, ...

WW: 01, 02, 03, ... voor week 1, week 2, week 3, ...

Zie, voor informatie over het opnieuw formeren van de condensatoren, *Converter module capacitor reforming instructions*(3BFE64059629 [Engels]), dat op internet te vinden is op www.abb.com/drives/documents.

Data

IEC nominale waarden

ACS880-31	Kabel (mm ²)	aR-zekering	Verliezen (W)
3-fase $U_N = 400\text{ V}$ (380...415 V)			
09A4-3	3×1,5	170M1561	226
12A6-3	3×1,5	170M1561	329
017A-3	3×6	170M1563	395
025A-3	3×6	170M1563	579
032A-3	3×10	170M1565	625
038A-3	3×10	170M1565	751
045A-3	3×16	170M1566	912
061A-3	3×25	170M1567	1088
072A-3	3×35	170M1568	1502
087A-3	3×50	170M1569	1904
105A-3	3×50	170M3817	1877
145A-3	3×95	170M3817	2963
169A-3	3×120	170M5809	3168
206A-3	3×150	170M5810	3990
3-fase $U_N = 500\text{ V}$ (380...500 V)			
07A6-5	3×1,5	170M1561	219
11A0-5	3×1,5	170M1561	278
014A-5	3×6	170M1563	321
021A-5	3×6	170M1563	473
027A-5	3×10	170M1565	625
034A-5	3×10	170M1565	711
040A-5	3×16	170M1566	807
052A-5	3×25	170M1567	960
065A-5	3×35	170M1568	1223
077A-5	3×35	170M1569	1560
101A-5	3×50	170M3816	1995
124A-5	3×95	170M3817	2800
156A-5	3×120	170M5808	3168
180A-5	3×150	170M5810	3872

3AXD00000588487

Kies de vermogenskabels

Zie [Data](#) op pagina 74.

Zorg voor koeling

Zie [Data](#) op pagina [74](#). Er is geen condensatie of vorst toegestaan. Het toegestane bedrijfstemperatuurbereik van de omvormer zonder derating is -15 tot +40 °C.

Beveilig de omvormer en de voedingskabel

Zie [Data](#) op pagina [74](#).

A – Installeer de omvormer aan de wand

Zie figuur [A](#) op pagina [137](#).

B – Verwijder de kap

Verwijder de kap/kappen Zie de figuren [B \(R3\)](#) en [B \(R6, R8\)](#)... op pagina [137](#).

C – Controleer de compatibiliteit met IT (ongeaarde) en hoekgeaarde driehoek-systemen

Zie figuur [C](#) op pagina [137](#).



WAARSCHUWING! Als de omvormer aangesloten wordt op een IT (ongeaard of hoogohmig geaard) systeem of op een hoekgeaard driehoek-systeem, ontkoppel dan het EMC-filter (optie +E202) en aarde-naar-fase varistor. Zie de hardwarehandleiding van de omvormer.

D – Controleer de isolatie van de vermogenskabels en de motor

Sluit de motorkabel aan de motorzijde aan. Voor minimale radiofrequentie-interferentie, dient de motorkabelafscherming over 360 graden geaard te worden bij de kabel invoer van het motorklemmenblok. Zie figuur [D](#) op pagina [137](#).

Controleer de isolatie van motor en motorkabel. Zie figuur [D](#) op pagina [137](#).

Opmerking: Vocht in de motorbehuizing zal de isolatieweerstand verlagen. Als u vocht vermoedt, moet u de motor drogen en de meting herhalen.

Controleer de isolatie van de ingangskabel alvorens deze aan te sluiten op de omvormer. Voldoe aan de plaatselijke regelgeving.

E – Bevestig de waarschuwingsstickers in plaatselijke talen

Zie figuur [E](#) op pagina [138](#).

F – Sluit de vermogenskabels aan

Gebruik symmetrisch afgeschermd kabel voor de motorbekabeling. Als de kabelafscherming de enige PE-geleider is, zorg er dan voor dat deze voldoende geleidbaar is voor de PE.

Opmerking voor frame R3: Zorg er voor dat u een extra PE-geleider in de ingangsvermogensbekabeling heeft. Zie de hardwarehandleiding voor meer informatie.

Procedure:

1. Frame R6 en R8: Verwijder de afdekking op de vermogenskabelklemmen. Zie figuur *F (R6, R8)*... op pagina 138. Frame R8: Verwijder de zijplaten om het installeren gemakkelijker te maken.
2. Verwijder de rubberen doorvoertules van de bodemplaat zodat de kabels aangesloten kunnen worden. Zie figuur *...F...* op pagina 138.
3. Snijd een geschikt gat in de rubberen doorvoertules. Schuif de doorvoertules op de kabels.
4. Maak de uiteinden van de kabels gereed. Zie figuur *...F...* op pagina 138.

De blote afscherming moet over 360 graden geaard worden. Markeer de pigtail die van de afscherming gemaakt is, als PE-geleider met een gele-en-groene kleur.

Er zijn twee alternatieve symmetrische drie-geleider kabeltypes getoond, en één vier-geleider kabeltype. De vier-geleider kabel is alleen toegestaan voor de ingangsvermogensbekabeling.

Als u aluminium kabels gebruikt, doe dan vet aan de gestripte aluminium kabel voordat u deze aansluit op de omvormer.

5. Schuif de kabels door de gaten van de kabelinvoerplaat en maak de doorvoertules in de gaten vast.
6. Sluit de kabels aan (gebruik de aanhaalmomenten die in de figuur gedefinieerd zijn). Zie de figuren *...F...* op pagina 138 en 139:
 - Aard de afscherming over 360 graden door de klem van de vermogenskabel-aardingsplaat vast te zetten op het gestripte gedeelte van de kabel.
 - Sluit de getwiste afscherming van de kabel aan op de aardklem.
 - Gebruik een afzonderlijke PE aardkabel (6a) of een kabel met een afzonderlijke PE-geleider (6b) als de conductiviteit van de afscherming niet voldoet aan de eisen voor de PE-geleider. Als de veiligheids-PE geleider kleiner is dan 10 mm^2 , moet u een tweede aardgeleider gebruiken. Zie de hardwarehandleiding voor meer informatie.
 - Frame R3: Sluit de extra PE-geleider van de ingangsvermogensbekabeling aan.

- Sluit de fasegeleiders van de motorkabel aan op klemmen T1/U, T2/V en T3/W en de fasegeleiders van de ingangskabel op de klemmen L1, L2 en L3.
7. Frame R6 types groter dan -040A-x: Snij gleufjes in de afdekking voor de geïnstalleerde kabels. Frame R8: Installeer de zijplaten, indien verwijderd. Druk gaten in de afdekking uit voor de ingangskabels. Zie figuur *...F (R6, R8)...* op pagina 139.
 8. Frames R6 en R8: Installeer de afdekking op de vermogenskabelklemmen. Zie figuur *...F (R6, R8)...* op pagina 139.
 9. Zet de kabels buiten de omvormer mechanisch vast.

G – Sluit de besturingskabels aan

Procedure:

1. Verwijder de frontkap(pen), indien nog niet verwijderd.
2. Frame R3: Til de besturingspaneel-houder omhoog. Zie figuur *G (R3)...* op pagina 139.
3. Snij een voldoende groot gat in de rubberen doorvoertule en schuif de doorvoertule op de kabel. Schuif de kabel door een gat in de bodemplaat en maak de doorvoertule in het gat vast.
4. Leid de kabels. Frame R3: Zie figuur *...G (R3)...* op pagina 139. Frame R6: Zie figuur *...G (R6)...* op pagina 139. Frame R8: Zie figuur *...G (R8)...* op pagina 140.
5. Aard de buitenste afscherming van de kabel over 360 graden onder de aardklem. Houd de kabel ongestript tot zo dicht mogelijk bij de klemmen van de besturingskaart.
6. Zet de kabels binnen de omvormer mechanisch vast.
7. Frame R3: Laat de kabelpaar-afschermingen aarddraden ontkoppeld aan de omvormerzijde, en aard deze aan het andere kabeluiteinde. Snijd eventuele onaangesloten kabels af aan de omvormerzijde. Frame R6 en R8: Aard de afschermingen van de kabelparen en aarddraad onder de klem beneden de besturingsunit.
8. Sluit de geleiders aan op de juiste klemmen van de besturingsunit. Zie *Standaard IO-aansluitschema* op pagina 79.
9. Bedraad de optionele modules indien deze bij de levering bijgevoegd zijn. Zie de gebruikershandleiding of installatiegids van de optiemodule.
10. Zet de kabels buiten de omvormer mechanisch vast.

Opmerking:

- Laat de andere uiteinden van de besturingskabel-afschermingen ontkoppeld.
- Houd alle signaaldraad-paren getwist tot zo dicht mogelijk bij de klemmen.

H – Zet de kap(pen) terug

Zie de figuren [H \(R3, R6, R8\)](#)... op pagina [140](#).

■ **Standaard IO-aansluitschema**

Aderafmetingen:
0,5 ... 2,5 mm²
(24...14 AWG)
Aanhaalmomenten:
0,5 N·m
(0,4 lbf·ft) voor
zowel gevlochten
als massieve
bedrading.

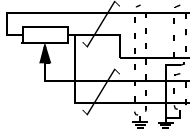

XPOW Externe hulpspanningsingang		
1	+24VI	24 V DC, 2 A
2	GND	

XAI Referentiespanning en analoge ingangen		
1	+VREF	10 V DC, R_L 1...10 kohm
2	-VREF	-10 V DC, R_L 1...10 kohm
3	AGND	Aarde
4	AI1+	Toerentalreferentie 0(2)...10 V, $R_{in} > 200$ kohm
5	AI1-	
6	AI2+	Standaard niet in gebruik. 0(4)...20 mA, $R_{in} = 100$ ohm
7	AI2-	
J1	J1	AI1 stroom/spanning selectiejumper
J2	J2	AI2 stroom/spanning selectiejumper

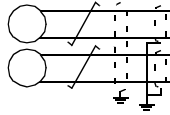

XAO Analoge uitgangen		
1	AO1	Motortoerental rpm 0...20 mA, $R_L < 500$ ohm
2	AGND	
3	AO2	Motorstroom 0...20 mA, $R_L < 500$ ohm
4	AGND	

XD2D Drive-to-drive link		
1	B	Drive-to-drive link
2	A	
3	BGND	
J3	J3	Afsluitingsjumper drive-to-drive link

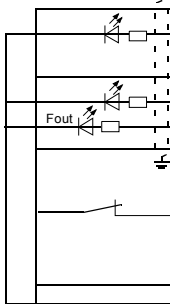

XRO1, XRO2, XRO3 Relaisuitgangen		
11	NC	Gereed 250 V AC/30 V DC 2 A
12	COM	
13	NO	In bedrijf 250 V AC/30 V DC 2 A
21	NC	
22	COM	Fout(-1) 250 V AC/30 V DC 2 A
23	NO	
31	NC	
32	COM	
33	NO	

XD24 Digitale blokkering		
1	DIIL	Runvrijgave
2	+24VD	+24 V DC 200 mA
3	DICOM	Aarde digitale ingang
4	+24VD	+24 V DC 200 mA
5	DIOGND	Aarde digitale ingang/uitgang
J6	Aarde selectiejumper	

XDIO Digitale ingang/uitgangen		
1	DIO1	Uitgang: Gereed
2	DIO2	Uitgang: In bedrijf

XDI Digitale ingangen		
1	DI1	Stop (0) / Start (1)
2	DI2	Voorwaarts (0) / Achterwaarts (1)
3	DI3	Reset
4	DI4	Acceleratie & deceleratie keuze
5	DI5	Constant toerental 1 (1 = Aan)
6	DI6	Standaard niet in gebruik.

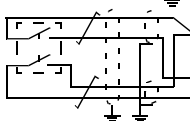

XSTO Safe torque off		
1	OUT1	Safe torque off. Beide circuits moeten gesloten zijn voordat de omvormer kan starten.
2	SGND	
3	IN1	
4	IN2	

X12	Aansluiting veiligheidsfuncties-module	
X13	Aansluiting bedieningspaneel	
X205	Aansluiting geheugenunit	

Verklaring van Overeenstemming (EU)

Power and productivity
for a better world™



EU Declaration of Conformity

Machinery Directive 2006/42/EC

We

Manufacturer: ABB Oy
Address: Hiomotie 13, 00380 Helsinki, Finland.
Phone: +358 10 22 11

declare under our sole responsibility that the following products:

Frequency converters

ACS880-01

ACS880-04/-04F

ACS880-M04

ACS880-11/-31/-14/-34

with regard to the built-in safety function:

Safe torque off;

and with regard to the following optional safety functions with FSO-12 module (option code +Q973, encoderless):

Safe stop 1; Safe stop emergency; Safely-limited speed; Safe maximum speed; Safe brake control; Prevention of Unexpected Start-up;

and with regard to the following optional safety functions (option codes +Q972 and +L521, encoder supported):

Safe stop 1; Safe stop emergency; Safely-limited speed; Safe maximum speed; Safe brake control; Safe speed monitor; Safe direction; Prevention of Unexpected Start-up;

and with regard to the following optional safety function with FPTC-01 thermistor protection module (option code +L536):

Safe Motor Temperature;

are in conformity with all the relevant safety component requirements of EU Machinery Directive 2006/42/EC, when the listed safety functions are used for safety component functionality.

Power and productivity
for a better world™



EU Declaration of Conformity

Machinery Directive 2006/42/EC

The following harmonized standards have been applied:

EN 61800-5-2:2007	<i>Adjustable speed electrical power drive systems – Part 5-2: Safety requirements - Functional</i>
EN 62061:2005 + AC:2010 + A1:2013 + A2:2015	<i>Safety of machinery – Functional safety of safety-related electrical, electronic and programmable electronic control systems</i>
EN ISO 13849-1:2015	<i>Safety of machinery – Safety-related parts of control systems. Part 1: General requirements</i>
EN ISO 13849-2:2012	<i>Safety of machinery – Safety-related parts of the control systems. Part 2: Validation</i>
EN 60204-1: 2006 + A1:2009 + AC:2010	<i>Safety of machinery – Electrical equipment of machines – Part 1: General requirements</i>

The following other standards have been applied:

IEC 61508:2010	<i>Functional safety of electrical / electronic / programmable electronic safety-related systems</i>
IEC 61800-5-2:2016	<i>Adjustable speed electrical power drive systems – Part 5-2: Safety requirements - Functional</i>

The products referred in this Declaration of conformity fulfil the relevant provisions of other European Union Directives which are notified in Single EU Declaration of conformity 3AXD10000497831.

Person authorized to compile the technical file:

Name and address: Juha Martinmaa, Hiomotie 13, 00380 Helsinki, Finland.

Helsinki, 15 Sep 2017

Manufacturer representative:

Vesa Kandell
Vice President, ABB Oy

3AXD10000099646

2 (2)

PL — Skrócona instrukcja montażu

Ta instrukcja zawiera krótki opis sposobu montażu przemiennika częstotliwości. Pełne instrukcje montażu zawiera podręcznik *ACS880-31 drives hardware manual* (3AXD50000045933 [j. ang.]). Instrukcje uruchamiania zawiera podręcznik *ACS880 drives with primary control program quick start-up guide* (3AUA0000098062 [j. ang.]).

Aby przeczytać podręcznik, przejdź na stronę www.abb.com/drives/documents i wyszukaj numer dokumentu.

Należy przestrzegać instrukcji bezpieczeństwa



OSTRZEŻENIE! Należy przestrzegać tych instrukcji. Nieprzestrzeganie instrukcji może skutkować obrażeniami, śmiercią lub uszkodzeniem urządzenia:

- Do montażu i konserwacji przemiennika częstotliwości uprawnieni są wyłącznie wykwalifikowani elektrycy.
- Nie można wykonywać żadnych prac przy przemienniku częstotliwości, kablu silnika ani silniku, jeśli podłączone jest źródło zasilania. Jeśli przemiennik częstotliwości jest już podłączony do zasilania, należy odczekać 5 minut po jego odłączeniu.
- Nie wolno nigdy wykonywać żadnych prac przy kablach sterowania, jeśli do przemiennika częstotliwości lub zewnętrznych obwodów sterowania doprowadzone jest zasilanie.
- Nie można podłączać przemiennika częstotliwości do napięcia wyższego niż podane na tabliczce znamionowej.
- Zawsze uziemić przemiennik częstotliwości, silnik oraz pobliskie urządzenia. do szyny uziemiającej (PE) zasilania.
- **Obudowy R6 i R8:** Moduł przemiennika częstotliwości jest ciężki i ma wysoko położony środek ciężkości. Do podnoszenia użyć podnośnika. Nie przechylać przemiennika. Podnoszenie ręczne lub przewrócenie w wyniku przechylenia może spowodować obrażenia ciała. Upewnić się, że ściana oraz mocowania są wystarczająco wytrzymałe, aby utrzymać ciężar modułu.
- Podczas montażu uważać, aby opiłki powstające w trakcie wiercenia i szlifowania nie przedostały się do wnętrza przemiennika częstotliwości.
- Upewnić się, że podłoga pod przemiennikiem częstotliwości i ściana, na której jest zainstalowany, nie są łatwopalne.

PL

Sprawdzenie, czy kondensatory wymagają formowania

Formowanie kondensatorów należy wykonać, jeśli przemiennik częstotliwości nie był włączany od ponad trzech lat (był w magazynie lub nie był używany).

Datę produkcji można określić na podstawie numeru seryjnego, który jest widoczny na tabliczce znamionowej przymocowanej do przemiennika częstotliwości. Numer

seryjny ma format MRRTRXXXX. RR i TT określają rok i tydzień produkcji w następujący sposób:

RR: 17, 18, 19, ... oznacza 2017, 2018, 2019, ...

TT: 01, 02, 03, ... to 1. tydzień, 2. tydzień, 3. tydzień, ...

Więcej informacji na temat formowania kondensatorów zawiera dokument *Converter module capacitor reforming instructions* (3BFE64059629 [j.ang.]), który jest dostępny na stronie internetowej www.abb.com/drives/documents.

Dane

Wartości znamionowe IEC

ACS880-31	Kabel (mm ²)	Bezpiecznik aR	Straty (W)
Trójfazowe $U_N = 400\text{ V}$ (380...415 V)			
09A4-3	3×1,5	170M1561	226
12A6-3	3×1,5	170M1561	329
017A-3	3×6	170M1563	395
025A-3	3×6	170M1563	579
032A-3	3×10	170M1565	625
038A-3	3×10	170M1565	751
045A-3	3×16	170M1566	912
061A-3	3×25	170M1567	1088
072A-3	3×35	170M1568	1502
087A-3	3×50	170M1569	1904
105A-3	3×50	170M3817	1877
145A-3	3×95	170M3817	2963
169A-3	3×120	170M5809	3168
206A-3	3×150	170M5810	3990
Trójfazowe $U_N = 500\text{ V}$ (380...500 V)			
07A6-5	3×1,5	170M1561	219
11A0-5	3×1,5	170M1561	278
014A-5	3×6	170M1563	321
021A-5	3×6	170M1563	473
027A-5	3×10	170M1565	625
034A-5	3×10	170M1565	711
040A-5	3×16	170M1566	807
052A-5	3×25	170M1567	960
065A-5	3×35	170M1568	1223
077A-5	3×35	170M1569	1560
101A-5	3×50	170M3816	1995
124A-5	3×95	170M3817	2800
156A-5	3×120	170M5808	3168
180A-5	3×150	170M5810	3872

3AXD00000588487

Dobór kabli zasilania

Patrz *Dane* na stronie 84.

Zapewnianie chłodzenia

Patrz *Dane* na stronie 84. Nie jest dopuszczalne skraplanie i oszronienie. Dozwolony zakres temperatury pracy przemiennika częstotliwości bez obniżenia jego wartości znamionowych wynosi od -15 do +40°C.

Ochrona przemiennika częstotliwości i kabla zasilania wejściowego

Patrz *Dane* na stronie 84.

A — montaż przemiennika częstotliwości na ścianie

Patrz rysunek *A* na stronie 137.

B — zdejmowanie pokrywy

Zdjąć pokrywę lub pokrywy. Patrz rysunki *B (R3)* i *B (R6, R8)*... na str. 137.

C — sprawdzanie zgodności z sieciami IT (bez uziemienia) i uziemionymi wierzchołkowo sieciami typu trójką

Patrz rysunek *C* na stronie 137:



OSTRZEŻENIE! Jeśli przemiennik częstotliwości będzie podłączony do sieci IT (bez uziemienia lub z uziemieniem przez rezystancję o wysokiej wartości) albo uziemionej wierzchołkowo sieci typu trójką, odłączyć filtr EMC (opcja +E202) i warystor uziemienie-faza. Więcej informacji znajduje się w podręczniku użytkownika przemiennika częstotliwości.

PL

D — sprawdzanie izolacji kabli zasilania i silnika

Podłączyć kabel silnika po stronie silnika. Aby zminimalizować zakłócenia radiowe, uziemić ekran kabla silnika obwodowo (360 stopni) przy przepuszczeniu kablowym do skrzynki z zaciskami silnika. Patrz rysunek *D* na stronie 137.

Sprawdzić izolację silnika i kabla silnika. Patrz rysunek *D* na stronie 137. **Uwaga:** Wilgoć wewnątrz obudowy silnika zmniejsza rezystancję izolacji. Jeśli istnieje prawdopodobieństwo obecności wilgoci, należy wysuszyć silnik i powtórzyć pomiar.

Sprawdzić izolację kabla wejściowego przed podłączeniem go do przemiennika częstotliwości. Należy przestrzegać lokalnych przepisów.

E — mocowanie nalepek ostrzegawczych w językach lokalnych

Patrz rysunek [E](#) na stronie [138](#):

F — podłączanie kabli zasilania

W okablowaniu silnika używać symetrycznego kabla ekranowanego. Jeśli ekran kabla jest pojedynczym przewodem uziomowym, upewnić się, że ma odpowiednią przewodność dla przewodu uziomowego.

Uwaga dotycząca obudowy R3: Upewnić się, że w wejściowym okablowaniu zasilania jest dodatkowy przewód uziomowy. Więcej informacji zawiera podręcznik użytkownika.

Procedura:

1. Obudowy R6 i R8: Zdjąć osłonę zacisków kabla zasilania. Patrz rysunek [F \(R6, R8\)](#)... na stronie [138](#): Obudowa R8: W celu łatwiejszego montażu zdjąć płyty boczne.
2. Wyjąć gumowe dławiki z dolnej płyty w miejscach, w których mają zostać wprowadzone kable. Patrz rysunek [...F...](#) na stronie [138](#):
3. Wyciąć odpowiednie otwory w gumowych dławikach. Nasunąć dławiki na kable.
4. Przygotować końcówki kabli. Patrz rysunek [...F...](#) na stronie [138](#):

Odsłonięty ekran będzie uziemiony na całym obwodzie. Oznaczyć końcówkę wykonaną z ekranu jako przewód uziomowy (PE) za pomocą kolorów żółtego i zielonego.

Pokazane są dwa alternatywne symetryczne kable z trzema przewodami i jeden kabel z czterema przewodami. Kabel z czterema przewodami jest dozwolony tylko w przypadku wejściowego okablowania zasilania.

Jeśli używane są kable aluminiowe, nałożyć smar na odsłonięty kabel aluminiowy przed podłączeniem do przemiennika częstotliwości.

5. Przeciągnąć kable przez otwory w płycie przepustowej kabli i zamocować dławiki w otworach.
6. Podłączyć kable (z momentem wskazanym na rysunku). Patrz rysunki [...F...](#) na str. [138](#) i [139](#):
 - Uziemić ekran kabla obwodowo, dokręcając zacisk listwy uziemiającej do odsłoniętej części kabla.
 - Podłączyć skręcany ekran kabla do zacisku uziomowego.
 - Należy użyć osobnego ochronnego przewodu uziomowego (6a) lub kabla z osobnym przewodem uziomowym (6b), jeśli przewodność ekranu nie spełnia wymagań ochronnego przewodu uziomowego. Jeśli ochronny przewód uziomowy jest mniejszy niż 10 mm², trzeba użyć drugiego przewodu uziomowego. Więcej informacji zawiera podręcznik użytkownika.

- Obudowa R3: Podłączyć dodatkowy przewód uziomowy w wejściowym okablowaniu zasilania.
 - Podłączyć przewody fazowe kabla silnika do zacisków T1/U, T2/V i T3/W oraz przewody fazowe kabla wejściowego do zacisków L1, L2 i L3.
7. Typy obudów R6 większe niż -040A-x: Wyciąć w osłonie miejsce dla zamontowanych kabli. Obudowa R8: Zamontować płyty boczne, jeśli zostały zdjęte. Wypchnąć w osłonie otwory dla kabli wejściowych. Patrz rysunek [...F \(R6, R8\)](#)... na stronie 139:
 8. Obudowy R6 i R8: Zamontować osłonę zacisków kabla zasilania. Patrz rysunek [...F \(R6, R8\)](#)... na stronie 139:
 9. Zabezpieczyć kable mechanicznie na zewnątrz przemiennika częstotliwości.

G — podłączanie kabli sterowania

Procedura

1. Zdjąć przednią osłonę (lub osłony), jeśli nie została jeszcze zdjęta.
2. Obudowa R3: Unieść uchwyt panelu sterowania. Patrz rysunek [G \(R3\)](#)... na stronie 139:
3. Wyciąć odpowiedni otwór w gumowym dławiku i nasunąć go na kabel. Przeciagnąć kabel przez otwór w płycie dolnej i zamocować dławik w tym otworze.
4. Poprowadzić kable. Obudowa R3: Patrz rysunek [...G \(R3\)](#)... na stronie 139: Obudowa R6: Patrz rysunek [...G \(R6\)](#)... na stronie 139: Obudowa R8: Patrz rysunek [...G \(R8\)](#)... na stronie 140:
5. Uziemić obwodowo zewnętrzny ekran kabla pod zaciskiem uziemiającym. Osłonięta część kabla powinna znajdować się jak najbliżej zacisków karty sterowania.
6. Zabezpieczyć kable mechanicznie wewnątrz przemiennika częstotliwości.
7. Obudowa R3: Pozostawić ekrany kabli dwużyłowych i przewody uziomowe niepodłączone po stronie przemiennika częstotliwości i uziemić je po drugiej stronie. Odciąć wszelkie niepodłączone przewody po stronie przemiennika częstotliwości. Obudowy R6 i R8: Uziemić ekrany kabli dwużyłowych oraz przewód uziomowy przy użyciu zacisku pod jednostką sterującą.
8. Podłączyć przewody do odpowiednich zacisków karty sterowania. Patrz [Schemat domyślnych połączeń we/wy](#) na stronie 89.
9. Podłączyć moduły opcjonalne, jeśli są częścią dostawy. Patrz podręcznik użytkownika modułu opcjonalnego lub instrukcja instalacji.
10. Zabezpieczyć kable mechanicznie na zewnątrz przemiennika częstotliwości.

Uwaga:

- Pozostawić drugie końce ekranów kabla sterowania niepodłączone.
- Pary kabla sygnałowego powinny być skręcone ze sobą możliwie najbliżej zacisków przyłączeniowych.

H — ponowne zakładanie pokryw

Patrz rysunki [H \(R3, R6, R8\)](#)... na stronie [140](#):

■ Schemat domyślnych połączeń we/wy

Rozmiary przewodów:
0.5 ... 2,5 mm²
(24...14 AWG)
Momenty dokręcania:
0,5 Nm
(0,4 lbf·ft) dla przewodów jedno- i wielodrutowych.

XPOW		Wejście zasilania zewnętrznego	
1	+24VI	24 V DC, 2 A	
2	GND		
XAI		Napięcie odniesienia i wejścia analogowe	
1	+VREF	10 V DC, R_L 1...10 k Ω	
2	-VREF	-10 V DC, R_L 1...10 k Ω	
3	AGND	Uziemienie	
4	AI1+	Wartość zadana prędkości 0(2)...10 V, $R_{in} > 200$ k Ω	
5	AI1-		
6	AI2+		
7	AI2-	Domyślnie nieużywane. 0(4)...20 mA, $R_{in} = 100$ Ω	
J1	J1	Zworka wyboru trybu pracy wejścia AI1 (prądowe/napięciowe)	
J2	J2	Zworka wyboru trybu pracy wejścia AI2 (prądowe/napięciowe)	
XAO		Wyjścia analogowe	
1	AO1	Prędkość silnika w obrotach na minutę 0...20mA, $R_L < 500$ Ω	
2	AGND		
3	AO2	Prąd silnika 0...20mA, $R_L < 500$ Ω	
4	AGND		
XD2D		Łącze drive-to-drive	
1	B	Łącze drive-to-drive	
2	A		
3	BGND		
J3	J3	Przełącznik terminacji łącza drive-to-drive	
XRO1, XRO2, XRO3		Wyjścia przekaźnikowe	
11	NC	Stan gotowości 250 V AC / 30 V DC 2 A	
12	COM		
13	NO	Bieg 250 V AC / 30 V DC 2 A	
21	NC		
22	COM	Błąd (-1) 250 V AC / 30 V DC 2 A	
23	NO		
31	NC	2 A	
32	COM		
33	NO		
XD24		Blokada cyfrowa	
1	DIIL	Zezwolenie na bieg	
2	+24VD	+24 V DC 200 mA	
3	DICOM	Masa wejścia cyfrowego	
4	+24VD	+24 V DC 200 mA	
5	DIOGND	Masa wejścia/wyjścia cyfrowego	
J6		Przełącznik wyboru masy	
XDIO		Wejścia/wyjścia cyfrowe	
1	DIO1	Wyjście: Stan gotowości	
2	DIO2	Wyjście: Bieg	
XDI		Wejścia cyfrowe	
1	DI1	Stop (0)/Start (1)	
2	DI2	Do przodu (0)/Do tyłu (1)	
3	DI3	Reset	
4	DI4	Wybór czasów przyspieszenia i zwolnienia	
5	DI5	Stała prędkość 1 (1 = Wł.)	
6	DI6	Domyślnie nieużywane.	
XSTO		Bezpieczne wyłączenie momentu	
1	OUT1	Bezpieczne wyłączenie momentu (STO).	
2	SGND	Oba obwody muszą być zamknięte, aby	
3	IN1	było możliwe uruchomienie przemiennika	
4	IN2	częstotliwości.	
X12	Złącze modułu funkcji bezpieczeństwa		
X13	Złącze panelu sterowania		
X205	Złącze modułu pamięci		

PL

Deklaracja zgodności (UE)

Power and productivity
for a better world™



EU Declaration of Conformity

Machinery Directive 2006/42/EC

We

Manufacturer: ABB Oy
Address: Hiomotie 13, 00380 Helsinki, Finland.
Phone: +358 10 22 11

declare under our sole responsibility that the following products:

Frequency converters

ACS880-01

ACS880-04/-04F

ACS880-M04

ACS880-11/-31/-14/-34

with regard to the built-in safety function:

Safe torque off;

and with regard to the following optional safety functions with FSO-12 module (option code +Q973, encoderless):

Safe stop 1; Safe stop emergency; Safely-limited speed; Safe maximum speed; Safe brake control; Prevention of Unexpected Start-up;

and with regard to the following optional safety functions (option codes +Q972 and +L521, encoder supported):

Safe stop 1; Safe stop emergency; Safely-limited speed; Safe maximum speed; Safe brake control; Safe speed monitor; Safe direction; Prevention of Unexpected Start-up;

and with regard to the following optional safety function with FPTC-01 thermistor protection module (option code +L536):

Safe Motor Temperature;

are in conformity with all the relevant safety component requirements of EU Machinery Directive 2006/42/EC, when the listed safety functions are used for safety component functionality.

Power and productivity
for a better world™



EU Declaration of Conformity

Machinery Directive 2006/42/EC

The following harmonized standards have been applied:

EN 61800-5-2:2007	<i>Adjustable speed electrical power drive systems – Part 5-2: Safety requirements - Functional</i>
EN 62061:2005 + AC:2010 + A1:2013 + A2:2015	<i>Safety of machinery – Functional safety of safety-related electrical, electronic and programmable electronic control systems</i>
EN ISO 13849-1:2015	<i>Safety of machinery – Safety-related parts of control systems. Part 1: General requirements</i>
EN ISO 13849-2:2012	<i>Safety of machinery – Safety-related parts of the control systems. Part 2: Validation</i>
EN 60204-1: 2006 + A1:2009 + AC:2010	<i>Safety of machinery – Electrical equipment of machines – Part 1: General requirements</i>

The following other standards have been applied:

IEC 61508:2010	<i>Functional safety of electrical / electronic / programmable electronic safety-related systems</i>
IEC 61800-5-2:2016	<i>Adjustable speed electrical power drive systems – Part 5-2: Safety requirements - Functional</i>

The products referred in this Declaration of conformity fulfil the relevant provisions of other European Union Directives which are notified in Single EU Declaration of conformity 3AXD10000497831.

Person authorized to compile the technical file:

Name and address: Juha Martinmaa, Hiomotie 13, 00380 Helsinki, Finland.

Helsinki, 15 Sep 2017

Manufacturer representative:

Vesa Kandell
Vice President, ABB Oy

3AXD10000099646

2 (2)

PT – Guia rápido de instalação

Este guia descreve resumidamente como instalar o acionamento. Para informação completa sobre a instalação, consulte *ACS880-31 drives hardware manual* (3AXD50000045933 [Inglês]). Para instruções sobre o arranque, consulte *ACS880 drives with primary control program quick start-up guide* (3AUA0000098062 [Inglês]).

Para ler um manual, aceda a www.abb.com/drives/documents e procure o número do documento.

Cumpra as instruções de segurança



AVISO! Cumprir estas instruções. Se ignorar as mesmas, podem ocorrer ferimentos ou morte, ou danos no equipamento:

- Apenas profissionais eletricitas qualificados estão autorizados a instalar e a reparar o acionamento.
- Nunca trabalhe no acionamento, no cabo do motor ou no motor com a alimentação aplicada. Se o acionamento já estiver ligado à entrada de alimentação, aguarde 5 minutos depois de desligar a alimentação de entrada.
- Nunca manipule os cabos de controlo quando a alimentação está aplicada ao acionamento ou aos circuitos de controlo externos.
- Não ligue o acionamento a uma tensão superior à assinalada na etiqueta de designação de tipo.
- Ligue sempre o acionamento, o motor e o equipamento circundante ao barramento da terra de proteção (PE) da alimentação de potência.
- Chassis R6 e R8: O módulo de acionamento é pesado e o seu centro de gravidade é elevado. Use um dispositivo de elevação para levantar a unidade. Não incline o acionamento. A elevação manual, ou a queda devido a inclinação, podem provocar ferimentos sérios. Certifique-se de que a parede e os dispositivos de fixação suportam o peso da unidade.
- Certifique-se que os resíduos resultantes das furações e outros não entram para o acionamento.
- Certifique-se de que o piso entre o acionamento e a parede onde este está instalado não é inflamável.

PT

Verifique se é necessário reformar os condensadores

Se o acionamento não estiver ligado (armazenado ou não usado) durante mais de três anos, é necessário reformar os condensadores.

É possível determinar a data de fabrico a partir do número de série, que se encontra na etiqueta de designação de tipo colada no acionamento. O número de série é do formato MYYWWRXXXX. YY e WW indicam o ano e a semana de fabrico como se segue:

YY: 17, 18, 19, ... para 2017, 2018, 2019, ...

WW: 01, 02, 03, ... para semana 1, semana 2, semana 3, ...

Para informações sobre a beneficiação de condensadores, consulte *Converter module capacitor reforming instructions* (3BFE64059629 [Inglês]), disponível na internet em www.abb.com/drives/documents.

Data

Gamas IEC

ACS880-31	Cabo (mm ²)	Fusível aR	Perdas (W)
Trifásico $U_N = 400$ V (380...415 V)			
09A4-3	3×1.5	170M1561	226
12A6-3	3×1.5	170M1561	329
017A-3	3×6	170M1563	395
025A-3	3×6	170M1563	579
032A-3	3×10	170M1565	625
038A-3	3×10	170M1565	751
045A-3	3×16	170M1566	912
061A-3	3×25	170M1567	1088
072A-3	3×35	170M1568	1502
087A-3	3×50	170M1569	1904
105A-3	3×50	170M3817	1877
145A-3	3×95	170M3817	2963
169A-3	3×120	170M5809	3168
206A-3	3×150	170M5810	3990
Trifásico $U_N = 500$ V (380...500 V)			
07A6-5	3×1.5	170M1561	219
11A0-5	3×1.5	170M1561	278
014A-5	3×6	170M1563	321
021A-5	3×6	170M1563	473
027A-5	3×10	170M1565	625
034A-5	3×10	170M1565	711
040A-5	3×16	170M1566	807
052A-5	3×25	170M1567	960
065A-5	3×35	170M1568	1223
077A-5	3×35	170M1569	1560
101A-5	3×50	170M3816	1995
124A-5	3×95	170M3817	2800
156A-5	3×120	170M5808	3168
180A-5	3×150	170M5810	3872

3AXD00000588487

PT

Selecionar os cabos de potência

Consulte [Data](#) na página 94.

Assegurar a refrigeração

Consulte [Data](#) na página [94](#). Não é permitida condensação ou congelamento. A gama de temperatura de operação permitida para o acionamento sem desclassificação é -15 para +40 °C.

Proteger o acionamento e o cabo de entrada de potência

Veja [Data](#) na página [94](#).

A – Instalar o acionamento na parede

Ver a figura [A](#) na página [137](#).

B – Remover a tampa

Remover a(s) tampa(s). Consultar as figuras [B \(R3\)](#) e [B \(R6, R8\)](#)... na página [137](#).

C – Verificar a compatibilidade com sistemas IT (sem ligação à terra) e sistemas delta de redes flutuantes

Consultar a figura [C](#) na página [137](#).



AVISO! Se o acionamento for ligado num sistema IT (sem ligação à terra ou de alta resistência) ou num sistema delta de redes flutuantes, desligue o filtro EMC (opção +E202) e o varistor terra-para-fase. Consulte o manual de hardware do acionamento.

D – Verificar o isolamento dos cabos de potência e do motor

Ligue o cabo do motor no lado do motor. Para uma interferência mínima de radiofrequência, ligue à terra a blindagem do cabo do motor a 360 graus na entrada de cabo da caixa de terminais do motor. Veja a figura [D](#) na página [137](#).

Verifique o isolamento do motor e do cabo do motor. Veja a figura [D](#) na página [137](#).
Nota: A presença de humidade no interior da caixa do motor reduz a resistência do isolamento. Se suspeitar da presença de humidade, seque o motor e volte a efetuar a medição.

Verifique o isolamento do cabo antes de o ligar ao acionamento. Cumpra os regulamentos locais.

E – Colocar os autocolante de aviso nos idiomas locais

Consultar a figura [E](#) na página [138](#).

F – Ligar os cabos de potência

Usar cabo de motor blindado simétrico para a cablagem do motor. Se a blindagem do cabo for o único condutor PE, certifique-se de que existe condutividade suficiente para o PE.

Nota para o chassis R3: Certifique-se de que tem um condutor PE adicional na cablagem de potência de entrada. Consulte o manual de hardware para mais informação.

Procedimento:

1. Chassis R6 e R8: Remova o acrílico nos terminais do cabo de potência. Veja a figura *F (R6, R8)*... na página 138. Chassis R8: Para uma instalação mais fácil, remova as placas laterais.
2. Remova os buçins de borracha da placa inferior para os cabos a serem ligados. Veja a figura *...F...* na página 138.
3. Corte um furo adequado nos buçins de borracha. Faça deslizar os buçins para os cabos.
4. Prepare as extremidades dos cabos. Veja a figura *...F...* na página 138.

A blindagem exposta será ligada à terra a 360 graus. Marque a espiral da blindagem como um condutor PE com a cor amarela e verde.

São apresentados, dois tipos alternativos de cabos simétricos de três condutores e um tipo de cabo de quatro condutores. O cabo de quatro condutores só é permitido para o cablagem de potência de entrada.

Se usar cabos de alumínio, lubrifique o cabo de alumínio descarnado antes de o ligar ao acionamento.

5. Passe os cabos através dos orifícios da placa de entrada de cabos e fixe os buçins aos orifícios.
6. Ligue os cabos (use os binários definidos na figura). Veja as figuras *...F...* na página 138 e 139:

- Ligue à terra a 360 graus as blindagens apertando o grampo da prateleira de ligação à terra do cabo de potência contra a parte descarnada do cabo.
- Ligue a blindagem entrançada do cabo ao terminal de ligação à terra.
- Use um cabo PE de ligação à terra separado (6a) ou um cabo com um condutor PE separado (6b) se a condutividade da blindagem não cumprir com os requisitos para o condutor PE. Se o condutor PE de proteção for inferior a 10 mm², deve usar um segundo condutor de ligação à terra. Consulte o manual de hardware para mais informação.
- Chassis R3: Ligue o condutor PE adicional à cablagem da potência de entrada.
- Ligue os condutores de fase do cabo do motor aos terminais T1/U, T2/V e T3/W e os condutores de fase do cabo de entrada aos terminais L1, L2 e L3.

7. Tipos de chassis R6 maiores que -040A-x: Corte guias no acrílico dos cabos instalados Chassis R8: Instale as placas laterais, se removidas. Faça os furos no acrílico para os cabos de entrada. Veja a figura [...F \(R6, R8\)...](#) na página [139](#).

8. Chassis R6 e R8: Instale o acrílico nos terminais do cabo de potência. Veja a figura *...F (R6, R8)...* na página 139.
9. Fixe mecanicamente os cabos no exterior do acionamento.

G – Ligar os cabos de controlo

Procedimento:

1. Retirar a(s) tampa(s) frontais se não tiverem sido já removidas.
2. Chassis R3: Levante o suporte da consola de programação. Veja a figura *G (R3)...* na página 139.
3. Corte um furo adequado no buçim de borracha e deslize o buçim pelo o cabo. Passe o cabo através de um orifício na placa inferior e fixe o buçim ao orifício.
4. Passar os cabos. Chassis R3: Veja a figura *...G (R3)...* na página 139. Chassis R6: Veja a figura *...G (R6)...* na página 139. Chassis R8: Veja a figura *...G (R8)...* na página 140.
5. Ligue à terra a blindagem exterior do cabo 360 graus debaixo do grampo de ligação à terra. Mantenha o cabo descarnado o mais próximo possível dos terminais da carta de controlo.
6. Fixe mecanicamente os cabos no interior do acionamento.
7. Chassis R3: Deixe o par das blindagens dos cabos e os cabos de ligação à terra desligados na extremidade do acionamento e ligue-os na outra extremidade do cabo. Corte todos os cabos não ligados na extremidade do acionamento. Chassis R6 e R8: Ligue à terra o par das blindagens dos cabos e os cabos de ligação à terra ao grampo por baixo da unidade de controlo.
8. Ligue os condutores aos terminais adequados da unidade de controlo. Consulte *Diagrama de ligação de E/S de fábrica* na página 99.
9. Ligue os módulos opcionais, se incluídos na entrega. Consulte o manual do utilizador do módulo ou o guia de instalação.
10. Fixe mecanicamente os cabos no exterior do acionamento.

PT

Nota:

- Deixe as outras extremidades das blindagens do cabo de controlo desligadas.
- Mantenha os pares do fio de sinal torcidos o mais próximo possível dos terminais.

H – Reinstalar a(s) tampa(s)

Veja as figuras *H (R3, R6, R8)...* na página 140.

■ Diagrama de ligação de E/S de fábrica

Tamanho cabos:
0.5 ... 2.5 mm²
(24...14 AWG)
Binários de
aperto: 0.5 N·m
(0.4 lbf·ft) para
cabos
enranchados e
sólidos.

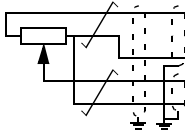

XPOW Entrada de potência externa

1	+24VI	24 V CC, 2 A
2	GND	

XAI Tensão de referência e entradas analógicas

1	+VREF	10 V CC, R_L 1...10 kohm
2	-VREF	-10 V CC, R_L 1...10 kohm
3	AGND	Terra
4	EA1+	Referência de velocidade 0(2)...10 V, R_{in} > 200 kohm
5	EA1-	
6	EA2+	Por defeito não usada. 0(4)...20 mA, R_{in} = 100 ohm
7	EA2-	
J1	J1	Jumper de seleção de corrente/tensão EA1
J2	J2	Jumper de seleção de corrente/tensão EA2

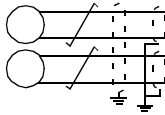

XAO Saídas analógicas

1	SA1	Rpm velocidade do motor 0...20 mA, R_L < 500 ohm
2	AGND	
3	SA2	Corrente motor 0...20 mA, R_L < 500 ohm
4	AGND	

XD2D Ligação acionamento-para-acionamento

1	B	Ligação acionamento-para-acionamento
2	A	
3	BGND	
J3	J3	Interruptor de ligação de terminação acionamento-para-acionamento

Saídas a relé XRO1, XRO2, XRO3

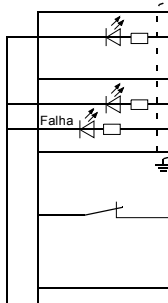

11	NF	Pronto 250 V CA / 30 V CC 2 A
12	COM	
13	NA	
21	NF	Operação 250 V CA / 30 V CC 2 A
22	COM	
23	NA	
31	NF	Falha(-1) 250 V CA / 30 V CC 2 A
32	COM	
33	NA	

XD24 Interlock digital

1	DIIL	Permissão func
2	+24VD	+24 V CC 200 mA
3	DICOM	Terra entrada digital
4	+24VD	+24 V CC 200 mA
5	DIOGND	Terra entrada/saída digital
J6	J6	Interruptor de seleção de terra

XDIO Entradas/saídas digitais

1	ESD1	Saída: Pronto
2	ESD2	Saída: Operação

XDI Entradas digitais

1	ED1	Parar (0) / Arrancar (1)
2	ED2	Direto (0) / Inverso (1)
3	ED3	Rearme
4	ED4	Seleção aceleração & desaceleração
5	ED5	Velocidade constante 1 (1 = On)
6	ED6	Por defeito não usada.

XSTO Binário seguro off

1	OUT1	Binário de segurança off. Ambos os circuitos devem estar fechados para o acionamento arrancar.
2	SGND	
3	IN1	
4	IN2	

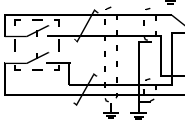

X12 Ligação do módulo de funções de segurança

X13 Ligação da consola de programação

X205 Ligação da unidade de memória

PT

Declaração de Conformidade (UE)

Power and productivity
for a better world™ 

EU Declaration of Conformity

Machinery Directive 2006/42/EC

We

Manufacturer: ABB Oy
Address: Hiomotie 13, 00380 Helsinki, Finland.
Phone: +358 10 22 11

declare under our sole responsibility that the following products:

Frequency converters

ACS880-01

ACS880-04/-04F

ACS880-M04

ACS880-11/-31/-14/-34

with regard to the built-in safety function:

Safe torque off;

and with regard to the following optional safety functions with FSO-12 module (option code +Q973, encoderless):

Safe stop 1; Safe stop emergency; Safely-limited speed; Safe maximum speed; Safe brake control; Prevention of Unexpected Start-up;

and with regard to the following optional safety functions (option codes +Q972 and +L521, encoder supported):

Safe stop 1; Safe stop emergency; Safely-limited speed; Safe maximum speed; Safe brake control; Safe speed monitor; Safe direction; Prevention of Unexpected Start-up;

and with regard to the following optional safety function with FPTC-01 thermistor protection module (option code +L536):

Safe Motor Temperature;

are in conformity with all the relevant safety component requirements of EU Machinery Directive 2006/42/EC, when the listed safety functions are used for safety component functionality.

Power and productivity
for a better world™



EU Declaration of Conformity

Machinery Directive 2006/42/EC

The following harmonized standards have been applied:

EN 61800-5-2:2007	<i>Adjustable speed electrical power drive systems – Part 5-2: Safety requirements - Functional</i>
EN 62061:2005 + AC:2010 + A1:2013 + A2:2015	<i>Safety of machinery – Functional safety of safety-related electrical, electronic and programmable electronic control systems</i>
EN ISO 13849-1:2015	<i>Safety of machinery – Safety-related parts of control systems. Part 1: General requirements</i>
EN ISO 13849-2:2012	<i>Safety of machinery – Safety-related parts of the control systems. Part 2: Validation</i>
EN 60204-1: 2006 + A1:2009 + AC:2010	<i>Safety of machinery – Electrical equipment of machines – Part 1: General requirements</i>

The following other standards have been applied:

IEC 61508:2010	<i>Functional safety of electrical / electronic / programmable electronic safety-related systems</i>
IEC 61800-5-2:2016	<i>Adjustable speed electrical power drive systems – Part 5-2: Safety requirements - Functional</i>

The products referred in this Declaration of conformity fulfil the relevant provisions of other European Union Directives which are notified in Single EU Declaration of conformity 3AXD10000497831.

Person authorized to compile the technical file:

Name and address: Juha Martinmaa, Hiomotie 13, 00380 Helsinki, Finland.

Helsinki, 15 Sep 2017

Manufacturer representative:

Vesa Kandell
Vice President, ABB Oy

3AXD10000099646

2 (2)

RU — Краткое руководство по монтажу

Настоящее руководство содержит краткое описание монтажа привода. Полная информация о монтаже приведена в документе *ACS880-31 drives hardware manual* (код английской версии 3AXD50000045933). Инструкции по вводу в эксплуатацию приведены в документе *ACS880 drives with primary control program quick start-up guide* (код английской версии 3AUA0000098062).

Чтобы загрузить руководство, перейдите на страницу www.abb.com/drives/documents и найдите документ с этим кодом.

Следуйте указаниям по технике безопасности



ПРЕДУПРЕЖДЕНИЕ! Неукоснительно следуйте данным указаниям.

Отказ от следования данным указаниям может повлечь за собой получение травмы, смерть или повреждение оборудования.

- К монтажу и техническому обслуживанию привода допускаются только квалифицированные электрики.
 - Запрещается выполнять какие-либо работы по обслуживанию привода, двигателя или кабеля двигателя при включенном питании. Если на привод подано напряжение питания, подождите по крайней мере 5 минут после отключения напряжения.
 - Запрещается выполнять какие-либо работы с кабелями управления при включенном питании привода или внешних цепей управления.
 - Запрещается подавать на привод напряжение выше указываемого на табличке с обозначением типа.
 - Обязательно выполните заземление привода, электродвигателя и сопряженного оборудования на шину защитного заземления (PE) источника питания.
 - Типоразмеры R6 и R8: Приводной модуль имеет большой вес, и его центр тяжести расположен высоко. Для подъема используйте подъемное устройство. Не наклоняйте привод. При подъеме вручную или в случае опрокидывания при подъеме возможны травмы. Убедитесь, что стена и фиксаторы могут выдержать необходимый вес.
 - Следите за тем, чтобы стружка, образующаяся при сверлении, резке и шлифовании, не попала внутрь привода.
 - Убедитесь, что пол под приводом и стена, на которой установлен привод, выполнены из негорючего материала.
-

Проверьте, не требуется ли формовка конденсаторов

Если на привод не подавалось питание (он находился на хранении или не использовался) более трех лет, выполните формовку конденсаторов.

Дату изготовления можно определить по серийному номеру, который указан на прикрепленной к приводу табличке с обозначением типа. Серийный номер имеет формат МYYWWRXXXX. YY и WW указывают год и неделю изготовления, а именно:

YY: 17, 18, 19, ... для 2017, 2018, 2019, ...

WW: 01, 02, 03, ... для 1-й недели, 2-й недели, 3-й недели, ...

Сведения о формовке конденсаторов см. в инструкции *Converter module capacitor reforming instructions* (код английской версии 3BFE64059629), которую можно загрузить в Интернете на странице www.abb.com/drives/documents.

Технические характеристики

Паспортные характеристики по IEC

ACS880-31	Кабель (мм ²)	Предохранитель aR	Потери (Вт)
3-фазн., $U_N = 400$ В (380...415 В)			
09A4-3	3 × 1,5	170M1561	226
12A6-3	3 × 1,5	170M1561	329
017A-3	3 × 6	170M1563	395
025A-3	3 × 6	170M1563	579
032A-3	3 × 10	170M1565	625
038A-3	3 × 10	170M1565	751
045A-3	3 × 16	170M1566	912
061A-3	3 × 25	170M1567	1088
072A-3	3 × 35	170M1568	1502
087A-3	3 × 50	170M1569	1904
105A-3	3 × 50	170M3817	1877
145A-3	3 × 95	170M3817	2963
169A-3	3 × 120	170M5809	3168
206A-3	3 × 150	170M5810	3990
3-фазн., $U_N = 500$ В (380...500 В)			
07A6-5	3 × 1,5	170M1561	219
11A0-5	3 × 1,5	170M1561	278
014A-5	3 × 6	170M1563	321
021A-5	3 × 6	170M1563	473
027A-5	3 × 10	170M1565	625
034A-5	3 × 10	170M1565	711
040A-5	3 × 16	170M1566	807
052A-5	3 × 25	170M1567	960
065A-5	3 × 35	170M1568	1223
077A-5	3 × 35	170M1569	1560
101A-5	3 × 50	170M3816	1995
124A-5	3 × 95	170M3817	2800
156A-5	3 × 120	170M5808	3168
180A-5	3 × 150	170M5810	3872

3AXD0000588487

RU

Выберите силовые кабели

См. раздел [Технические характеристики](#) на стр. 105.

Обеспечьте надлежащее охлаждение

См. раздел [Технические характеристики](#) на стр. 105. Образование конденсата или инея не допускается. Допустимый диапазон рабочих температур привода, в котором не наблюдается снижение рабочих характеристик, составляет от -15 до $+40$ °C.

Защитите привод и входной силовой кабель от повреждений

См. раздел *Технические характеристики* на стр. 105.

A — Закрепите привод на стене

См. рис. A на стр. 137.

B — Снимите крышку

Снимите крышку (крышки). См. рис. B (R3) и B (R6, R8)... на стр. 137.

C — Проверьте совместимость с системами IT (незаземленные сети) и системами с заземленной вершиной треугольника

См. рис. C на стр. 137.



ПРЕДУПРЕЖДЕНИЕ! В случае подключения привода к системе IT (незаземленная или с высокоомным заземлением) или к системе с заземленной вершиной треугольника отсоедините ЭМС-фильтр (дополнительный компонент +E202) и варистор земля-фаза. См. руководство по монтажу и эксплуатации привода.

D — Проверьте изоляцию силовых кабелей и двигателя

Подключите кабель двигателя со стороны двигателя. Для сведения радиочастотных помех к минимуму обеспечьте заземление экрана кабеля двигателя по полной окружности (360 градусов) на кабельном вводе в клеммной коробке двигателя. См. рис. D на стр. 137.

RU

Проверьте изоляцию двигателя и кабеля двигателя. См. рис. D на стр. 137.

Примечание. Наличие влаги внутри корпуса двигателя приводит к снижению сопротивления изоляции. Если имеется подозрение о наличии влаги, просушите двигатель и повторите измерение.

Перед тем как подключать сетевой кабель к приводу, проверьте его изоляцию. Соблюдайте местные нормы и правила.

E — Прикрепите предупреждающие наклейки на местных языках

См. рис. E на стр. 138.

F — Подключите силовые кабели

Для подключения двигателя используйте симметричный экранированный кабель. Если экран кабеля является единственным проводником защитного заземления (PE), убедитесь, что проводимость экрана достаточна для защитного заземления.

Замечание по поводу типоразмера R3: Убедитесь в том, что сетевом кабеле имеется дополнительный проводник защитного заземления (PE).

Дополнительная информация приведена в руководстве по монтажу и вводу в эксплуатацию.

Процедура:

1. **Типоразмеры R6 и R8:** Снимите кожух с клемм силовых кабелей. См. рис. *F (R6, R8)*... на стр. 138. **Типоразмер R8:** Для удобства монтажа снимите боковые панели.
2. Удалите резиновые манжеты из нижней пластины для ввода подключаемых кабелей. См. рис. *...F...* на стр. 138.
3. Прорежьте в резиновых манжетах отверстия требуемого размера. Наденьте манжеты на кабели.
4. Подготовьте концы кабелей. См. рис. *...F...* на стр. 138.
 Обнаженный экран заземляется по всей окружности (360 градусов).
 Пометьте косичку из экрана как PE-проводник зеленым и желтым цветом.
 Показаны симметричные трехжильные кабели двух типов и четырехжильный кабель одного типа, которые также можно использовать. Четырехжильный кабель разрешается использовать только для подключения к сети.
 При использовании алюминиевого кабеля нанесите смазку на зачищенную часть алюминиевого кабеля перед подключением к приводу.
5. Проложите кабели через отверстия в пластине для ввода кабелей и закрепите манжеты в отверстиях.
6. Подключите кабели (крутящие моменты затяжки указаны на рис.). См. рис. *...F...* на стр. 138 и 139:
 - Заземлите экран по всей окружности (360 градусов), затянув зажим полки заземления силового кабеля вокруг зачищенной части кабеля.
 - Подключите скрученный экран кабеля к клемме заземления.
 - Если проводимость экрана не соответствует требованиям для PE-проводника, используйте отдельный заземляющий PE-кабель (6a) или кабель с отдельным PE-проводником (6b). Если сечение защитного проводника PE меньше 10 мм^2 , следует использовать второй проводник заземления. Дополнительная информация приведена в руководстве по монтажу и вводу в эксплуатацию.

- Типоразмер R3: Подключите дополнительный проводник защитного заземления (PE) сетевого кабеля.
 - Подключите фазные проводники кабеля двигателя к клеммам T1/U, T2/V и T3/W, а фазные проводники сетевого кабеля — к клеммам L1, L2 и L3.
7. Типоразмеры R6, превышающие -040A-х: Срежьте выступы на кожухе для установленных кабелей. Типоразмер R8: Установите боковые панели, если они были сняты. Пройдите отверстия в кожухе для сетевых кабелей. См. рис. ...F (R6, R8)... на стр. 139.
 8. Типоразмеры R6 и R8: Установите кожух на клеммы силовых кабелей. См. рис. ...F (R6, R8)... на стр. 139.
 9. Обеспечьте механическое крепление кабелей вне привода.

G — Подключите кабели управления

Процедура:

1. Снимите передние крышки, если они еще не сняты.
2. Типоразмер R3: Поднимите держатель панели управления вверх. См. рис. G (R3)... на стр. 139.
3. Прорежьте отверстие требуемого размера в резиновой манжете и наденьте манжету на кабель. Пропустите кабель сквозь отверстие в нижней панели и закрепите манжету в отверстии.
4. Проложите кабели. Типоразмер R3: См. рис. ...G (R3)... на стр. 139. Типоразмер R6: См. рис. ...G (R6)... на стр. 139. Типоразмер R8: См. рис. ...G (R8)... на стр. 140.
5. Заземлите внешний экран кабеля по всей окружности (360 градусов) зажимом заземления. Незащищенная часть кабеля должна как можно ближе подходить к клеммам платы управления.
6. Обеспечьте механическое крепление кабелей внутри привода.
7. Типоразмер R3: Оставьте экраны кабелей типа «витая пара» и провода заземления неподсоединенными на стороне привода и заземлите их на другом конце кабеля. Обрежьте неподсоединенные провода на стороне привода. Типоразмеры R6 и R8: Заземлите экраны кабелей типа «витая пара» и провод заземления под зажимом, расположенным ниже блока управления.
8. Подключите проводники к соответствующим клеммам блока управления. См. *Стандартная схема подключения входов/выходов* на стр. 110.
9. Подключите дополнительные модули, если они включены в комплект поставки. См. руководство пользователя или руководство по монтажу дополнительного модуля.
10. Обеспечьте механическое крепление кабелей вне привода.

Примечание.

- Оставьте другие концы экранов кабелей управления неподсоединенными.
- Сигнальные пары кабеля управления должны быть скручены как можно ближе к клеммам.

H — Установите ранее снятую крышку (крышки)

См. рис. [H \(R3, R6, R8\)](#)... на стр. [140](#).

Стандартная схема подключения входов/выходов

Сечение проводов:
0,5 ... 2,5 мм²
(24... 14 AWG)
Моменты затяжки:
0,5 Н·м как для многожильного, так и для сплошного провода.

ХР0W		Вход внешнего питания
1	+24V1	24 В=, 2 А
2	GND	
ХА1		Опорное напряжение и аналоговые входы
1	+VREF	10 В=, R _L 1...10 кОм
2	-VREF	-10 В=, R _L 1...10 кОм
3	AGND	Земля
4	AI1+	Задание скорости 0(2)...10 В, R _{in} > 200 кОм
5	AI1-	
6	AI2+	По умолчанию не используется. 0(4)...20 мА, R _{in} = 100 Ом
7	AI2-	
J1	J1	Переключатель выбора тока/напряжения AI1
J2	J2	Переключатель выбора тока/напряжения AI2
ХАО		Аналоговые выходы
1	AO1	Скорость двигателя, об/мин 0...20 мА, R _L < 500 Ом
2	AGND	
3	AO2	Ток двигателя 0...20 мА, R _L < 500 Ом
4	AGND	
ХД2D		Линия связи привод-привод
1	B	Линия связи привод-привод
2	A	
3	BGND	
J3	J3	Выключатель оконечной нагрузки линии связи привод-привод
ХR01, ХR02, ХR03		Релейные выходы
11	NC	Готов 250 В~ / 30 В= 2 А
12	COM	
13	NO	
21	NC	Работа 250 В~ / 30 В= 2 А
22	COM	
23	NO	
31	NC	Отказ (-1) 250 В~ / 30 В= 2 А
32	COM	
33	NO	
ХД24		Цифровая взаимная блокировка
1	DIIL	Разрешение работы
2	+24VD	+24 В=, 200 мА
3	DICOM	Земля цифровых входов
4	+24VD	+24 В=, 200 мА
5	DIOGND	Земля цифровых входов/выходов
J6		Переключатель выбора заземления
ХДИ0		Цифровые входы/выходы
1	DIO1	Выход: Готов
2	DIO2	Выход: Работа
ХДИ		Цифровые входы
1	DI1	Стоп (0) / Пуск (1)
2	DI2	Вперед (0) / Назад (1)
3	DI3	Сброс
4	DI4	Выбор разгона и замедления
5	DI5	Постоянная скорость 1 (1 = ВКЛ)
6	DI6	По умолчанию не используется.
ХSTO		Безопасное отключение крутящего момента
1	OUT1	Функция безопасного отключения крутящего момента. Для пуска привода необходимо замкнуть обе цепи.
2	SGND	
3	IN1	
4	IN2	
Х12		Подключение модуля функций защиты
Х13		Подключение панели управления
Х205		Подключение блока памяти

Декларация соответствия (ЕС)

Power and productivity
for a better world™



EU Declaration of Conformity

Machinery Directive 2006/42/EC

We

Manufacturer: ABB Oy
Address: Hiomotie 13, 00380 Helsinki, Finland.
Phone: +358 10 22 11

declare under our sole responsibility that the following products:

Frequency converters

ACS880-01

ACS880-04/-04F

ACS880-M04

ACS880-11/-31/-14/-34

with regard to the built-in safety function:

Safe torque off;

and with regard to the following optional safety functions with FSO-12 module (option code +Q973, encoderless):

Safe stop 1; Safe stop emergency; Safely-limited speed; Safe maximum speed; Safe brake control; Prevention of Unexpected Start-up;

and with regard to the following optional safety functions (option codes +Q972 and +L521, encoder supported):

Safe stop 1; Safe stop emergency; Safely-limited speed; Safe maximum speed; Safe brake control; Safe speed monitor; Safe direction; Prevention of Unexpected Start-up;

and with regard to the following optional safety function with FPTC-01 thermistor protection module (option code +L536):

Safe Motor Temperature;

are in conformity with all the relevant safety component requirements of EU Machinery Directive 2006/42/EC, when the listed safety functions are used for safety component functionality.

EU Declaration of Conformity

Machinery Directive 2006/42/EC

The following harmonized standards have been applied:

EN 61800-5-2:2007	<i>Adjustable speed electrical power drive systems – Part 5-2: Safety requirements - Functional</i>
EN 62061:2005 + AC:2010 + A1:2013 + A2:2015	<i>Safety of machinery – Functional safety of safety-related electrical, electronic and programmable electronic control systems</i>
EN ISO 13849-1:2015	<i>Safety of machinery – Safety-related parts of control systems. Part 1: General requirements</i>
EN ISO 13849-2:2012	<i>Safety of machinery – Safety-related parts of the control systems. Part 2: Validation</i>
EN 60204-1: 2006 + A1:2009 + AC:2010	<i>Safety of machinery – Electrical equipment of machines – Part 1: General requirements</i>

The following other standards have been applied:

IEC 61508:2010	<i>Functional safety of electrical / electronic / programmable electronic safety-related systems</i>
IEC 61800-5-2:2016	<i>Adjustable speed electrical power drive systems – Part 5-2: Safety requirements - Functional</i>

The products referred in this Declaration of conformity fulfil the relevant provisions of other European Union Directives which are notified in Single EU Declaration of conformity 3AXD10000497831.

Person authorized to compile the technical file:

Name and address: Juha Martinmaa, Hiomotie 13, 00380 Helsinki, Finland.

Helsinki, 15 Sep 2017

Manufacturer representative:



Vesa Kandell
Vice President, ABB Oy

SV – Snabbguide för installation

Denna guide beskriver i korthet hur frekvensomriktaren installeras. För komplett information om installation, se *ACS880-31 drives hardware manual* (3AXD50000045933 [engelska]). För idrifttagningsinstruktioner, se *ACS880 drives with primary control program quick start-up guide* (3AUA0000098062 [engelska]).

Handledningarna finns att läsa på www.abb.com/drives/documents. Sök efter dokumentnumret.

Följ säkerhetsinstruktionerna



WARNING! Följ dessa instruktioner. Om instruktionerna inte följs kan det orsaka personskador eller dödsfall eller skador på utrustningen:

- Endast kvalificerad elektriker får installera och underhålla frekvensomriktaren.
- Arbeta aldrig med frekvensomriktaren, motorkabeln eller motorn när nätspänning är ansluten. Om frekvensomriktaren är ansluten till matningsspänning, vänta 5 minuter efter att den har fränskilts.
- Arbeta aldrig med styrkablarna om frekvensomriktaren eller dess externa styrkretsar är spänningsatta.
- Anslut inte frekvensomriktaren till en spänning som är högre än markeringen på märkskylten.
- Jorda alltid frekvensomriktaren, motorn och ansluten utrustning till strömförsörjningens skyddsjordledaren (PE).
- Byggstorlekarna R6 och R8: Frekvensomriktarmodulen är tung och har hög tyngdpunkt. Använd en lyftanordning för lyft. Luta inte frekvensomriktaren. Manuella lyft, eller att frekvensomriktaren välter gå grund av lyft, kan orsaka personskador. Kontrollera att väggen och fästnanordningarna kan bära vikten.
- Var noga med att inga borrh- eller slipspån kommer in i frekvensomriktaren.
- Var noga med att golvet under frekvensomriktaren och väggen där frekvensomriktaren är installerad är av icke brännbart material.

SV

Kontrollera om kondensatorerna måste reformeras

Om frekvensomriktaren inte har varit i drift (antingen i förvaring eller inte använts) på över tre år måste kondensatorerna reformeras.

Tillverkningsdatumet kan fastställas med serienumren som finns på märkskylten på frekvensomriktaren. Serienumret är i formatet MÅÄVVRXXXX. ÅÅ och VV visar tillverkningsår och -vecka enligt följande:

ÅÅ: 17, 18, 19, ... för 2017, 2018, 2019, ...

VV: 01, 02, 03, ... för vecka 1, vecka 2, vecka 3, ...

För information om reformering av kondensatorer, se *Converter module capacitor reforming instructions* (3BFE64059629 [engelska]), på Internet på www.abb.com/drives/documents.

Data

IEC-märkdata

ACS880-31	Kabel (mm ²)	aR-säkring	Förluster (W)
3-fas $U_N = 400$ V (380...415 V)			
09A4-3	3×1,5	170M1561	226
12A6-3	3×1,5	170M1561	329
017A-3	3×6	170M1563	395
025A-3	3×6	170M1563	579
032A-3	3×10	170M1565	625
038A-3	3×10	170M1565	751
045A-3	3×16	170M1566	912
061A-3	3×25	170M1567	1088
072A-3	3×35	170M1568	1502
087A-3	3×50	170M1569	1904
105A-3	3×50	170M3817	1877
145A-3	3×95	170M3817	2963
169A-3	3×120	170M5809	3168
206A-3	3×150	170M5810	3990
3-fas $U_N = 500$ V (380...500 V)			
07A6-5	3×1,5	170M1561	219
11A0-5	3×1,5	170M1561	278
014A-5	3×6	170M1563	321
021A-5	3×6	170M1563	473
027A-5	3×10	170M1565	625
034A-5	3×10	170M1565	711
040A-5	3×16	170M1566	807
052A-5	3×25	170M1567	960
065A-5	3×35	170M1568	1223
077A-5	3×35	170M1569	1560
101A-5	3×50	170M3816	1995
124A-5	3×95	170M3817	2800
156A-5	3×120	170M5808	3168
180A-5	3×150	170M5810	3872

3AXD00000588487

SV

Val av kraftkablär

Se *Data* på sidan 114.

Kontrollera att kylningen är tillfredsställande

Se *Data* på sidan 114. Ingen kondens eller frost tillåts. Tillåtet driftstemperaturområde för frekvensomriktaren utan nedstämpling är -15 till +40°C.

Skydd för frekvensomriktaren och matningskabeln

Se *Data* på sidan 114.

A – Installera frekvensomriktaren på vägg

Se figur *A* på sidan 137.

B – Ta bort kåpan

Ta bort kåpan/kåporna. Se figurerna *B (R3)* och *B (R6, R8)*... på sidan 137.

C – Kontrollera kompatibilitet med IT-system (icke-direktjordade) och hörnjordade delsystem

Se figur *C* på sidan 137.



WARNING! Om frekvensomriktaren ska anslutas till ett IT-system (ojordad eller högresistivt jordad eller ett hörnjordad delsystem ska EMC-filtret (tillval +E202) och jord till fas-varistorn fränkopplas. Se frekvensomriktarens hårdvaruhandledning.

D – Kontrollera isolationen hos matningskablarna och motorn

Anslut motorkabeln vid motorändan. För att minimera den radiofrekventa strålningen, jorda motorkabelskärmen 360° runt om vid kabelgenomföringen i motorns anslutningslåda. Se figur *D* på sidan 137.

Kontrollera isolationen på motor och motorkablar. Se figur *D* på sidan 137. **Obs!** Fukt inuti motorkapslingen minskar isolationsresistansen. Om fukt misstänks, torka motorn och upprepa mätningen.

Kontrollera den inkommande kabelns isolation innan den ansluts till frekvensomriktaren. Följ lokala föreskrifter.

E – Sätt fast varningsetiketten på det lokala språket

Se figur *E* på sidan 138.

F – Anslut kraftkablarna

Använd symmetrisk skärmd kabel för motoranslutning. Om kabelskärmen är den enda skyddsjordledaren, se till att den har tillräcklig konduktivitet för skyddsjorden.

Not för byggstorlek R3: Se till att ha en extra PE-ledare i matningsspänningskablarna. Se hårdvaruhandledningen för mer information.

Procedur:

1. Byggstorlek R6 och R8: Ta bort kåpan på kraftkabelanslutningarna. Se figur [F \(R6, R8\)](#)... på sidan [138](#). Byggstorlek R8: Ta bort sidoplattorna för enklare installation.
2. Ta bort gummgomföringarna från bottenplattan för kablar som ska anslutas. Se figur [...F...](#) på sidan [138](#).
3. Skär ett lämpligt hål genom gummgomföringarna. För upp kragarna på kablarna.
4. Förbered kablarnas ändar. Se figur [...F...](#) på sidan [138](#).
Den frilagda skärmen ska jordas 360°. Markera skärmledarna som PE-ledare med gul och grön färg.
Två alternativa symmetriska treledarkabeltyper visas och en fyrledarkabeltyp. Fyrledarkabeln är bara tillåten för matningskablarna.
Om aluminiumkablar används, smörj den skalade aluminiumkabeln innan den ansluts till frekvensomriktaren.
5. För kablarna genom hålen i kabelingångsplattan och fäst genomföringarna i hålen.
6. Anslut kablarna (använd de moment som anges i figuren). Se figuren [...F...](#) på sidan [138](#) och [139](#):
 - Jorda den exponerade kabelskärmen 360 grader genom att dra åt matningskabelns jordningsklämma.
 - Anslut den tvinnade kabelskärmänden till jordplinten.
 - Använd en separat PE-kabel (6a) eller en kabel med separat PE-ledare (6b) om skärmens konduktivitet inte uppfyller kraven på PE-ledare. Om skyddsjordledaren är mindre än 10 mm² måste ytterligare en jordledare användas. Se hårdvaruhandledningen för mer information.
 - Byggstorlek R3: Anslut matningskablarnas extra PE-ledare.
 - Anslut motorkabelns fasledare till klämmorna T1/U, T2/V och T3/W, och matningskabelns fasledare till klämmorna L1, L2 och L3.
7. Typer i byggstorlek R6 som är större än -040A-x: Klipp flikar i kåpan för de installerade kablarna. Byggstorlek R8: Sätt tillbaka sidoplattorna om de har tagits bort. Öppna de förberedda hålen i kåpan för matningskablarna. Se figur [...F \(R6, R8\)](#)... på sidan [139](#).

8. Byggstorlekarna R6 och R8: Sätt på kåpan på kraftkabelanslutningarna. Se figur [...F \(R6, R8\)...](#) på sidan [139](#).
9. Fixera mekaniskt alla kablar utanför frekvensomriktaren.

G – Anslut styrkablarna

Procedur:

1. Ta bort frontkåpan om den inte redan är borttagen.
2. Byggstorlek R3: Lyft upp manöverpanelen. Se figur [G \(R3\)...](#) på sidan [139](#).
3. Skär ett lämpligt hål i gummigenomföringen i anslutningslådans underdel och skjut upp genomföringen på kabeln. För kabeln genom ett hål i bottenplattan och fäst gummigenomföringen i hålet.
4. Förlägg kablarna. Byggstorlek R3: Se figur [...G \(R3\)...](#) på sidan [139](#). Byggstorlek R6: Se figur [...G \(R6\)...](#) på sidan [139](#). Byggstorlek R8: Se figur [...G \(R8\)...](#) på sidan [140](#).
5. Jorda den yttre kabelskärmen 360 grader under jordningsklämman. Skala upp och anslut kabelskärmen så nära styrkortens plintar som möjligt.
6. Fixera mekaniskt alla kablar innanför frekvensomriktaren.
7. Byggstorlek R3: Låt ledarparens skärmar och jordledare vara oanslutna i frekvensomriktaränden och jorda dem i den andra kabeländen. Skär av oanslutna kablar i frekvensomriktaränden. Byggstorlek R6 och R8: Jorda ledarparens skärmar och jordledaren under jordningsöverfallet under styrenheten.
8. Anslut ledarna till respektive plintar på styrenheten. Se [Förvalt IO-kretsschema](#) på sidan [118](#).
9. Anslut tillvalsmodulerna om de har medföljt leveransen. Se tillvalsmodulens användarhandledning eller installationsguide.
10. Fixera mekaniskt alla kablar utanför frekvensomriktaren.

Obs!

- Lämna skärmarnas motsatta ändar oanslutna.
- Låt signalledarparen vara tvinnade så nära anslutningarna som möjligt.

SV

H – Sätt tillbaka kåpan/kåporna

Se figurerna [H \(R3, R6, R8\)...](#) på sidan [140](#).

Förvalt IO-kretsschema

Ledar-
dimensioner:
0,5 ... 2,5 mm²
(24...14 AWG)
åtdragnings-
moment: 0,5 Nm
för både
mångtrådiga och
enkelledare.

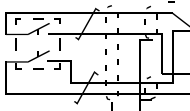
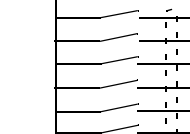
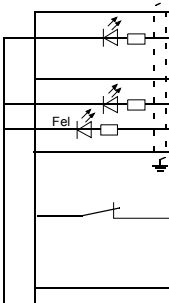
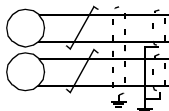
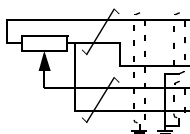

XPOW Extern matning		
1	+24VI	24 V DC, 2 A
2	GND	
XAI Referensspänning och analoga ingångar		
1	+VREF	10 V DC, R_i 1...10 kohm
2	-VREF	-10 V DC, R_i 1...10 kohm
3	AGND	Jord
4	AI1+	Varvvalsreferens 0(2)...10 V, $R_{in} > 200$ kohm
5	AI1-	
6	AI2+	Används normalt ej. 0(4)...20 mA, $R_{in} = 100$ ohm
7	AI2-	
J1	J1	AI1 ström/spänning, valbygel
J2	J2	AI2 ström/spänning, valbygel
XAO Analoga utgångar		
1	AO1	Motorvarvtal 0...20 mA, $R_L < 500$ ohm
2	AGND	
3	AO2	Motorström 0...20 mA, $R_L < 500$ ohm
4	AGND	
XD2D Drift till drift-buss		
1	B	Drift till drift-buss
2	A	
3	BGND	
J3	J3	Bygel för terminering av drift till drift-buss
XRO1, XRO2, XRO3 Reläutgångar		
11	NC	Driftklar 250 V AC/30 V DC 2 A
12	COM	
13	NO	
21	NC	Drift 250 V AC/30 V DC 2 A
22	COM	
23	NO	
31	NC	Fel(-1) 250 V AC/30 V DC 2 A
32	COM	
33	NO	
XD24 Digital föreggling		
1	DIIL	Driftfrigivning
2	+24VD	+24 V DC 200 mA
3	DICOM	Jord för digitala ingångar
4	+24VD	+24 V DC 200 mA
5	DIOGND	Jord för digitala in-/utgångar
J6		Omkopplare för val av jord
XDIO Digitala in-/utgångar		
1	DIO1	Utgång: Driftklar
2	DIO2	Utgång: Drift
XDI Digitala ingångar		
1	DI1	Stopp (0)/Start (1)
2	DI2	Fram (0)/Back (1)
3	DI3	Återställning
4	DI4	Val av accelerations-/retardationsramp
5	DI5	Konstant varvtal 1 (1 = På)
6	DI6	Används normalt ej.
XSTO Safe torque off		
1	OUT1	Safe torque off. Båda kretsarna måste vara slutna för att frekvensomriktaren skall starta.
2	SGND	
3	IN1	
4	IN2	
X12	Anslutning för säkerhetsfunktionsmodul	
X13	Anslutning för manöverpanel	
X205	Anslutning för minnesenhet	

Försäkran om överensstämmelse (EU)

Power and productivity
for a better world™



EU Declaration of Conformity

Machinery Directive 2006/42/EC

We

Manufacturer: ABB Oy
Address: Hiomotie 13, 00380 Helsinki, Finland.
Phone: +358 10 22 11

declare under our sole responsibility that the following products:

Frequency converters

ACS880-01

ACS880-04/-04F

ACS880-M04

ACS880-11/-31/-14/-34

with regard to the built-in safety function:

Safe torque off;

and with regard to the following optional safety functions with FSO-12 module (option code +Q973, encoderless):

Safe stop 1; Safe stop emergency; Safely-limited speed; Safe maximum speed; Safe brake control; Prevention of Unexpected Start-up;

and with regard to the following optional safety functions (option codes +Q972 and +L521, encoder supported):

Safe stop 1; Safe stop emergency; Safely-limited speed; Safe maximum speed; Safe brake control; Safe speed monitor; Safe direction; Prevention of Unexpected Start-up;

and with regard to the following optional safety function with FPTC-01 thermistor protection module (option code +L536):

Safe Motor Temperature;

are in conformity with all the relevant safety component requirements of EU Machinery Directive 2006/42/EC, when the listed safety functions are used for safety component functionality.



EU Declaration of Conformity

Machinery Directive 2006/42/EC

The following harmonized standards have been applied:

EN 61800-5-2:2007	<i>Adjustable speed electrical power drive systems – Part 5-2: Safety requirements - Functional</i>
EN 62061:2005 + AC:2010 + A1:2013 + A2:2015	<i>Safety of machinery – Functional safety of safety-related electrical, electronic and programmable electronic control systems</i>
EN ISO 13849-1:2015	<i>Safety of machinery – Safety-related parts of control systems. Part 1: General requirements</i>
EN ISO 13849-2:2012	<i>Safety of machinery – Safety-related parts of the control systems. Part 2: Validation</i>
EN 60204-1: 2006 + A1:2009 + AC:2010	<i>Safety of machinery – Electrical equipment of machines – Part 1: General requirements</i>

The following other standards have been applied:

IEC 61508:2010	<i>Functional safety of electrical / electronic / programmable electronic safety-related systems</i>
IEC 61800-5-2:2016	<i>Adjustable speed electrical power drive systems – Part 5-2: Safety requirements - Functional</i>

The products referred in this Declaration of conformity fulfil the relevant provisions of other European Union Directives which are notified in Single EU Declaration of conformity 3AXD10000497831.

Person authorized to compile the technical file:

Name and address: Juha Martinmaa, Hiomotie 13, 00380 Helsinki, Finland.

Helsinki, 15 Sep 2017

Manufacturer representative:

Vesa Kandell
Vice President, ABB Oy

TR – Hızlı montaj kılavuzu

Bu kılavuzda sürücünün montajı kısaca anlatılmaktadır. Montajla ilgili tüm bilgiler için bkz. *ACS880-31 drives hardware manual* (3AXD50000045933 [İngilizce]). Devreye alma talimatları için, bkz. *ACS880 drives with primary control program quick start-up guide* (3AUA0000098062 [İngilizce]).

Çevrimiçi kılavuzu okumak için www.abb.com/drives/documents adresine gidin ve belge numarasını arayın.

Güvenlik talimatlarına uyun



UYARI! Bu talimatlara uyun. Bunlara uymamanız halinde ölüm ya da yaralanma söz konusu olabilir veya ekipman zarar görebilir.

- Sürücünün kurulumu ve bakımı sadece yetkili elektrik uzmanları tarafından yapılmalıdır.
- Enerji verildiğinde sürücü, motor kablosu ve motor üzerinde hiçbir işlem yapmayın. Sürücü zaten giriş gücüne bağlıysa giriş gücü bağlantısını kestikten sonra 5 dakika bekleyin.
- Sürücü veya harici kontrol devrelerine enerji verilirken kontrol kabloları üzerinde asla çalışma yapmayın.
- Sürücüyü tip tanımlama etiketinde belirtilenden daha yüksek gerilime bağlamayın.
- Sürücüyü, motoru ve bitişik ekipmanları her zaman güç kaynağının koruyucu topraklama (PE) barasına topraklayın.
- **R6 ve R8 kasalar:** Sürücü modülü ağırdır ve ağırlık merkezi yüksektir. Kaldırırken bir kaldırma cihazı kullanın. Sürücüyü yana yatırmayın. Sürücünün elle kaldırılması veya yana yatırma sonucu devrilmesi fiziksel yaralanmalara yol açabilir. Duvarın ve sabitleme cihazlarının ağırlığı taşıyabildiğinden emin olun.
- Delme, kesme ve zımparalama işlemlerinden kaynaklanan döküntülerin sürücünün içine girmemesine dikkat edin.
- Sürücünün altındaki zeminin ve sürücünün kurulduğu yerdeki duvarın yanmaz nitelikte olduğundan emin olun.

Kondansatörlerin yenilenmesinin gerekip gerekmediğini kontrol edin

Sürücüye üç yıldan uzun süre güç verilmemişse (depolanmışsa veya kullanılmıyorsa) kondansatörleri yenilemelisiniz.

Üretim tarihini, sürücünün üzerindeki tip tanımlama etiketinde bulabileceğiniz seri numarasından belirleyebilirsiniz. Seri numarası MYYWWRXXXX biçimindedir. YY ile WW üretim yılını ve haftasını gösterir.

YY: 2017, 2018, 2019, ... için 17, 18, 19, ...
 WW: hafta 1, hafta 2, hafta 3, ... için 01, 02, 03, ...

Kondansatörlerin yenilenmesi ile ilgili bilgi için, bkz. *Converter module capacitor reforming instructions* (3BFE64059629 [İngilizce]), İnternet'te www.abb.com/drives/documents adresinde bulunmaktadır.

Seçim tablosu

IEC değerleri

ACS800-31	Kablo (mm ²)	aR sigorta	Kayıplar (W)
3 fazlı $U_N = 400\text{ V}$ (380...415 V)			
09A4-3	3×1,5	170M1561	226
12A6-3	3×1,5	170M1561	329
017A-3	3×6	170M1563	395
025A-3	3×6	170M1563	579
032A-3	3×10	170M1565	625
038A-3	3×10	170M1565	751
045A-3	3×16	170M1566	912
061A-3	3×25	170M1567	1088
072A-3	3×35	170M1568	1502
087A-3	3×50	170M1569	1904
105A-3	3×50	170M3817	1877
145A-3	3×95	170M3817	2963
169A-3	3×120	170M5809	3168
206A-3	3×150	170M5810	3990
3 fazlı $U_N = 500\text{ V}$ (380...500 V)			
07A6-5	3×1,5	170M1561	219
11A0-5	3×1,5	170M1561	278
014A-5	3×6	170M1563	321
021A-5	3×6	170M1563	473
027A-5	3×10	170M1565	625
034A-5	3×10	170M1565	711
040A-5	3×16	170M1566	807
052A-5	3×25	170M1567	960
065A-5	3×35	170M1568	1223
077A-5	3×35	170M1569	1560
101A-5	3×50	170M3816	1995
124A-5	3×95	170M3817	2800
156A-5	3×120	170M5808	3168
180A-5	3×150	170M5810	3872

3AXD00000588487

TR

Güç kablolarını seçin

Bkz. [Seçim tablosu](#), sayfa 122.

Soğutmayı sağlayın

Bkz. [Seçim tablosu](#), sayfa 122. Yoğuşmaya veya donmaya izin verilmez. Değer kaybı olmadan sürücünün izin verilen çalışma sıcaklığı aralığı -15 ile +40°C'dir.

Sürücüyü ve giriş güç kablosunu koruyun

Bkz. [Seçim tablosu](#), sayfa 122.

A – Sürücüyü duvara monte edin

Bkz. şekil [A](#), sayfa 137.

B – Kapağı çıkarın

Kapağı/kapakları çıkarın. Bkz. şekil [B \(R3\)](#) ve [B \(R6, R8\)](#)..., sayfa 137.

C – IT (topraklamasız) ve köşede topraklamalı üçgen sistemlerle uyumluluğu kontrol edin

Bkz. şekil [C](#), sayfa 137.



UYARI! Sürücü bir IT (topraklamasız ya da yüksek dirençli topraklamalı) sisteme veya köşede topraklamalı üçgen sisteme bağlanacaksa EMC filtresini (opsiyon +E202) ve toprak-faz varistörünü sökün. Sürücü donanım kılavuzuna bakın.

D – Güç kablolarının ve motorun yalıtımını kontrol edin

Motor kablosunu motor tarafına bağlayın. Minimum radyo frekansı paraziti için motor kablosu blendajını, motor terminal kutusunun kablo girişinde 360 derece topraklayın. Bkz. şekil [D](#), sayfa 137.

Motor ve motor kablosu yalıtımını kontrol edin. Bkz. şekil [D](#), sayfa 137. **Not:** Motor muhafazası içindeki nem yalıtım direncini düşürecektir. Nemden şüphe edilirse motoru kurutun ve ölçümü tekrarlayın.

Sürücüye bağlamadan önce giriş kablosunun yalıtımını kontrol edin. Yerel düzenlemelere uyun.

E – Yerel dillerdeki uyarı etiketlerini yapıştırın

Bkz. şekil [E](#), sayfa 138.

F – Güç kablolarını bağlayın

Motor kablosu için simetrik blendajlı kablo kullanın. Kablo blendajı tek PE iletkeniyse blendajın iletkenliğinin PE için yeterli olduğundan emin olun.

R3 kasa için not: Giriş güç kablolarında ek bir PE iletkeniniz olduğundan emin olun. Daha fazla bilgi için donanım kılavuzuna bakın.

Prosedür:

1. R6 ve R8 kasa: Güç kablosu terminallerinin üzerindeki muhafazayı çıkarın. Bkz. şekil *F (R6, R8)...*, sayfa 138. R8 kasa: Kurulumu kolaylaştırmak için yan plakaları çıkarın.
2. Kabloların bağlanması için lastik rondelaları alt plakadan çıkarın. Bkz. şekil *...F...*, sayfa 138.
3. Lastik rondelalara uygun boyutlu bir delik açın. Rondelaları kabloların üzerine doğru kaydırın.
4. Kablo uçlarını hazırlayın. Bkz. şekil *...F...*, sayfa 138.

Çıplak blendaj 360 derece topraklanmalıdır. Blendajdan yapılan örgüyü, sarı ve yeşil rengi kullanarak bir PE iletkeni olarak işaretleyin.

İki adet alternatif simetrik üç iletkenli kablo türü ve bir adet dört iletkenli kablo türü gösterilmektedir. Dört iletkenli kabloya yalnızca giriş güç kabloları için izin verilir.

Alüminyum kablo kullanıyorsanız, sürücüyü bağlamadan önce soyulmuş alüminyum kabloya yağ sürün.

5. Kabloları, kablo giriş plakası deliklerinin içinden geçirin ve rondelaları deliklere takın.
6. Kabloları bağlayın (şekilde tanımlanan momentleri kullanın). Bkz. şekiller *...F...* sayfa 138 ve 139:
 - Güç kablosu topraklama rafının kelepçesini kablonun soyulmuş kısmının üzerinde sıkıştırarak blendajı 360 derece topraklayın.
 - Kablonun bükümlü blendajını topraklama terminaline bağlayın.
 - Blendajın iletkenliği PE iletkeni gerekliliğini karşılamıyorsa, ayrı bir topraklama PE kablosu (6a) veya ayrı bir PE iletkenine sahip bir kablo (6b) kullanın. Koruyucu PE iletkeni 10 mm²'den küçükse ikinci bir topraklama iletkeni kullanmalısınız. Daha fazla bilgi için donanım kılavuzuna bakın.
 - R3 kasa: Giriş güç kablolarının ek PE iletkenini bağlayın.
 - Motor kablosunun faz iletkenlerini T1/U, T2/V ve T3/W terminallerine ve giriş kablosunun faz iletkenlerini L1, L2 ve L3 terminallerine bağlayın.
7. -040A-x üzeri R6 kasalar tipleri: Takılı kablolar için muhafazada çıkıntılar kesin. R8 kasa: Çıkarılmışsa yan plakaları takın. Giriş kabloları için muhafazada delikler açın. Bkz. şekil *...F (R6, R8)...*, sayfa 139.

8. R6 ve R8 kasalar: Muhafazayı güç kablosu terminallerinin üzerine takın. Bkz. şekil ...[F \(R6, R8\)](#)..., sayfa [139](#).
9. Kabloları sürücünün dışına mekanik olarak sabitleyin.

G – Kontrol kablolarını bağlayın

Prosedür:

1. Zaten çıkarılmamışsa ön kapağı/kapakları çıkarın.
2. R3 kasa: Kontrol paneli yuvasını yukarı kaldırın. Bkz. şekil [G \(R3\)](#)..., sayfa [139](#).
3. Lastik rondelaya uygun boyutlu bir delik açın ve rondelayı kablounun üstüne kaydırın. Kabloyu alt plaka deliğinin içinden geçirin ve rondelayı deliğe takın.
4. Kabloları döşeyin. R3 kasa: Bkz. şekil ...[G \(R3\)](#)..., sayfa [139](#).
R6 kasa: Bkz. şekil ...[G \(R6\)](#)..., sayfa [139](#). R8 kasa: Bkz. şekil ...[G \(R8\)](#)..., sayfa [140](#).
5. Dış kablo blendajını topraklama kelepçesinin altında 360 derece topraklayın. Kabloyu, kontrol paneli terminallerine mümkün olduğunca yakına kadar soyulmamış halde tutun.
6. Kabloları sürücünün içine mekanik olarak sabitleyin.
7. R3 kasa: Kablo çifti blendajlarını ve topraklama kablolarını sürücü ucunda boşta bırakın ve diğer kablo ucunda topraklayın. Sürücü ucunda boştaki tüm kabloları kesin. R6 ve R8 kasa: Kablo çifti blendajlarını ve topraklama kablosunu kontrol ünitesinin altındaki kelepçenin altında topraklayın.
8. İletkenleri kontrol ünitesinin uygun terminallerine bağlayın. Bkz. [Varsayılan GÇ bağlantı diyagramı](#), sayfa [126](#).
9. Teslimata dahil olmaları halinde opsiyonel modüllerin kablolarını bağlayın. Opsiyonel modül kullanım kılavuzuna veya kurulum kılavuzuna bakın.
10. Kabloları sürücünün dışına mekanik olarak sabitleyin.

Not:

- Kontrol kablosu blendajlarının diğer uçlarını boşta bırakın.
- Bükülü sinyal kablosu çiftlerini terminallere mümkün olduğunca yakın tutun.

H – Kapağı/kapakları tekrar takın

Bkz. şekiller [H \(R3, R6, R8\)](#)..., sayfa [140](#).

Varsayılan GÇ bağlantı diyagramı

Kablo boyutları:
0,5 ... 2,5 mm²
(24... 14 AWG)
Sıkma momentleri:
Hem telli hem som kablo için
0,5 N·m
(0,4 lbf·ft).

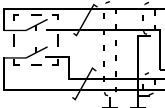
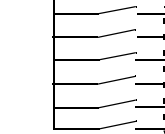
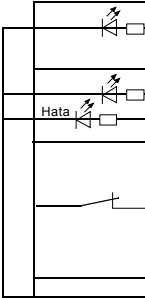
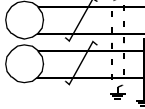
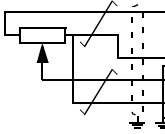

XPOW Harici güç girişi

1	+24V	24 VDC, 2 A
2	GND	

XAI Referans gerilimi ve analog girişler

1	+VREF	10 VDC, R_L 1...10 kohm
2	-VREF	-10 VDC, R_L 1...10 kohm
3	AGND	Topraklama
4	AI1+	Hız referansı 0(2)...10 V, $R_{in} > 200$ kohm
5	AI1-	
6	AI2+	Varsayılan olarak kullanımda değildir.
7	AI2-	
J1	J1	AI1 akım/gerilim seçim jumper'ı
J2	J2	AI2 akım/gerilim seçim jumper'ı

XAO Analog çıkışlar

1	AO1	Motor hızı rpm 0...20 mA, $R_L < 500$ ohm
2	AGND	
3	AO2	Motor akımı 0...20 mA, $R_L < 500$ ohm
4	AGND	

XD2D Sürücü - sürücü bağlantısı

1	B	Sürücü - sürücü bağlantısı
2	A	
3	BGND	
J3	J3	Sürücü - sürücü bağlantısı sonlandırma anahtarı

XRO1, XRO2, XRO3 Röle çıkışları

11	NC	Hazır 250 VAC / 30 VDC 2 A
12	COM	
13	NO	
21	NC	Çalışıyor 250 VAC / 30 VDC 2 A
22	COM	
23	NO	
31	NC	Hatalı(-1) 250 VAC / 30 VDC 2 A
32	COM	
33	NO	

XD24 Dijital kilit

1	DIIL	Çalışma izni
2	+24 VD	+24 VDC 200 mA
3	DICOM	Dijital giriş toprak hattı
4	+24 VD	+24 VDC 200 mA
5	DIOGND	Dijital giriş/çıkış toprak hattı
J6		Toprak seçim anahtarı

XDIO Dijital giriş/çıkışlar

1	DIO1	Çıkış: Hazır
2	DIO2	Çıkış: Çalışıyor

XDI Dijital girişler

1	DI1	Stop (0) / Start (1)
2	DI2	İleri (0) / Geri (1)
3	DI3	Reset
4	DI4	Hızlanma ve yavaşlama seçimi
5	DI5	Sabit hız 1 (1 = Açık)
6	DI6	Varsayılan olarak kullanımda değildir.

XSTO Güvenli moment kapatma

1	OUT1	Güvenli moment kapatma. Sürücünün başlaması için her iki devre kapatılmalıdır.
2	SGND	
3	IN1	
4	IN2	

X12 Güvenlik fonksiyonları modülü bağlantısı

X13 Kontrol paneli bağlantısı

X205 Hafıza kartı bağlantısı

Uygunluk Beyanı (AB)

Power and productivity
for a better world™



EU Declaration of Conformity

Machinery Directive 2006/42/EC

We

Manufacturer: ABB Oy
Address: Hiomotie 13, 00380 Helsinki, Finland.
Phone: +358 10 22 11

declare under our sole responsibility that the following products:

Frequency converters

ACS880-01

ACS880-04/-04F

ACS880-M04

ACS880-11/-31/-14/-34

with regard to the built-in safety function:

Safe torque off;

and with regard to the following optional safety functions with FSO-12 module (option code +Q973, encoderless):

Safe stop 1; Safe stop emergency; Safely-limited speed; Safe maximum speed; Safe brake control; Prevention of Unexpected Start-up;

and with regard to the following optional safety functions (option codes +Q972 and +L521, encoder supported):

Safe stop 1; Safe stop emergency; Safely-limited speed; Safe maximum speed; Safe brake control; Safe speed monitor; Safe direction; Prevention of Unexpected Start-up;

and with regard to the following optional safety function with FPTC-01 thermistor protection module (option code +L536):

Safe Motor Temperature;

are in conformity with all the relevant safety component requirements of EU Machinery Directive 2006/42/EC, when the listed safety functions are used for safety component functionality.

Power and productivity
for a better world™



EU Declaration of Conformity

Machinery Directive 2006/42/EC

The following harmonized standards have been applied:

EN 61800-5-2:2007	<i>Adjustable speed electrical power drive systems – Part 5-2: Safety requirements - Functional</i>
EN 62061:2005 + AC:2010 + A1:2013 + A2:2015	<i>Safety of machinery – Functional safety of safety-related electrical, electronic and programmable electronic control systems</i>
EN ISO 13849-1:2015	<i>Safety of machinery – Safety-related parts of control systems. Part 1: General requirements</i>
EN ISO 13849-2:2012	<i>Safety of machinery – Safety-related parts of the control systems. Part 2: Validation</i>
EN 60204-1: 2006 + A1:2009 + AC:2010	<i>Safety of machinery – Electrical equipment of machines – Part 1: General requirements</i>

The following other standards have been applied:

IEC 61508:2010	<i>Functional safety of electrical / electronic / programmable electronic safety-related systems</i>
IEC 61800-5-2:2016	<i>Adjustable speed electrical power drive systems – Part 5-2: Safety requirements - Functional</i>

The products referred in this Declaration of conformity fulfil the relevant provisions of other European Union Directives which are notified in Single EU Declaration of conformity 3AXD10000497831.

Person authorized to compile the technical file:

Name and address: Juha Martinmaa, Hiomotie 13, 00380 Helsinki, Finland.

Helsinki, 15 Sep 2017

Manufacturer representative:

Vesa Kandell
Vice President, ABB Oy

中文 – 快速安装指南

本指南简要介绍如何安装变频器。有关安装的完整信息，请参阅 **ACS880-31 变频器硬件手册** (3AXD50000045933 [中文])。有关启动说明，请参阅 **ACS880 配有主用控制程序之变频器快速启动指南** (3AUA0000098062 [中文])。

如需阅读手册，请访问 www.abb.com/drives/documents，搜索文件编号。

遵循安全指导



警告！ 请遵循这些指导。如果您忽略指导，可能会导致受伤、死亡或设备损坏。

- 仅允许由具备资质的专业电工对变频器进行安装和维护。
- 当接上主电源时，切勿对变频器、电机电缆或电机进行操作。如果变频器已经连接到了输入电源，请在断开输入电源后等待 5 分钟。
- 当变频器或外部控制电路连接了电源时，切勿操作控制电缆。
- 切勿将变频器连接到带有高于型号标签上所标数值之电压的电源。
- 请务必将变频器、电机和相邻设备接到电路的保护接地 (PE) 总线上。
- **机架 R6 和 R8:** 变频器模块很重，而且重心较高。请使用吊运工具来将其吊起。不要将变频器倾斜。手动搬起时或由于倾斜而侧翻时均有可能造成人身伤害。确保墙壁和固定装置能承载此重量。
- 确保不要让钻孔、切割和研磨所产生的碎屑进入变频器。
- 确保变频器下方的地面和安装变频器的墙面是阻燃的。

检查电容是否需要重整

如果变频器已经有三年或更长时间未通电（存放或未用），则必须重整电容。

您可以从序列号来确定生产日期，序列号可以在变频器所贴的型号标签上找到。序列号的格式为 MYYWWRXXXX。YY 和 WW 以如下方式说明生产年份和周次：

YY: 17、18、19、... 分别代表 2017 年、2018 年、2019 年、...

WW: 01、02、03、... 分别代表第 1 周、第 2 周、第 3 周、...

有关电容重整的信息，请参阅互联网上的 *Converter module capacitor reforming instructions* (变频器模块电容重整说明) (3BFE64059629 [英语])，网址：www.abb.com/drives/documents。

数据

IEC 额定值

ACS880-31	电缆 (mm ²)	aR 熔断器	损耗 (W)
3-相 $U_N = 400\text{ V}$ (380...415 V)			
09A4-3	3×1.5	170M1561	226
12A6-3	3×1.5	170M1561	329
017A-3	3×6	170M1563	395
025A-3	3×6	170M1563	579
032A-3	3×10	170M1565	625
038A-3	3×10	170M1565	751
045A-3	3×16	170M1566	912
061A-3	3×25	170M1567	1088
072A-3	3×35	170M1568	1502
087A-3	3×50	170M1569	1904
105A-3	3×50	170M3817	1877
145A-3	3×95	170M3817	2963
169A-3	3×120	170M5809	3168
206A-3	3×150	170M5810	3990
3-相 $U_N = 500\text{ V}$ (380...500 V)			
07A6-5	3×1.5	170M1561	219
11A0-5	3×1.5	170M1561	278
014A-5	3×6	170M1563	321
021A-5	3×6	170M1563	473
027A-5	3×10	170M1565	625
034A-5	3×10	170M1565	711
040A-5	3×16	170M1566	807
052A-5	3×25	170M1567	960
065A-5	3×35	170M1568	1223
077A-5	3×35	170M1569	1560
101A-5	3×50	170M3816	1995
124A-5	3×95	170M3817	2800
156A-5	3×120	170M5808	3168
180A-5	3×150	170M5810	3872

3AXD0000588487

选择电源电缆

请参阅第 130 页的 [数据](#)。

ZH 确保冷却

请参阅第 130 页的 [数据](#)。不允许出现凝露或结霜。在不降低额定值的情况下，变频器的允许工作温度范围为 -15 到 +40 °C。

保护变频器和输入电缆

请参阅第 130 页的 [数据](#)。

A - 将变频器安装到墙上

请参阅第 137 页的图 [A](#)。

B - 取下盖板

取下盖板请参阅第 137 页的图 [B \(R3\)](#) 和 [B \(R6, R8\)...](#)。

C - 检查与 IT（浮地）和角接地三角形系统的兼容性

请参阅第 137 页的图 [C](#)。



警告！ 如果变频器将要连接至 IT（浮地或高阻接地）系统或 B 相接地三角形系统，则应断开 EMC 滤波器（选装件 +E202）以及压敏电阻。请参阅变频器硬件手册。

D - 检查电源电缆和电机的绝缘

在电机端连接电机电缆为尽量降低射频干扰，在电机接线盒的电缆入口处将电机电缆屏蔽层做 360 度接地。请参阅第 137 页的图 [D](#)。

检查电机和电机电缆的绝缘。请参阅第 137 页的图 [D](#)。**注意：**电机外壳内部的湿气会降低绝缘电阻。如果湿气长期存在，请干燥电机后再次测量。

在将输入电缆连接到变频器前，请检查其绝缘。请遵循当地法律法规。

E - 贴上以当地语言写成的警告贴纸

请参阅第 138 页的图 [E](#)。

F - 连接电源电缆

请使用对称屏蔽电缆进行电机电缆敷设。如果电缆屏蔽层是唯一的保护接地导体，请确保它具有保护接地所需的充分导电能力。

机架 R3 注意事项：请确保您在输入电源电缆敷设中配备了额外的保护接地导体。请参阅硬件手册了解更多信息。

程序：

1. **机架 R6 和 R8：**将电源电缆端子上的护罩取下。请参阅第 138 页的图 [F \(R6, R8\)...](#)。**机架 R8：**为便于安装，请取下侧板。
2. 将橡胶索环从底板上取下，以便安装电缆。请参阅第 138 页的图 [...F...](#)。

3. 在橡胶索环上切出适当大小的孔。将索环套到电缆上。
4. 将电缆末端准备好。请参阅第 138 页的图 ...F...。
裸屏蔽层将 360 度接地。使用黄绿双色将由屏蔽层制成的接地辫标记为保护接地导体。
图中显示了两种备选的对称三芯电缆以及一种四芯电缆。四芯电缆仅可用作输入电源电缆。
如果使用铝缆，则请在剥开的铝缆上涂上润滑脂，然后再将其连接到变频器上。
5. 将电缆从引线板的孔中穿过并将索环固定到孔上。
6. 连接电缆（使用图中规定的扭矩）。请参阅第 138 页和第 139 页中的图 ...F...:
 - 将电源电缆夹的接地支架紧固到电缆的剥开部分，使屏蔽层 360 度接地。
 - 将电缆的双绞线屏蔽层连接到接地端子。
 - 如果屏蔽层的导电能力不能满足保护接地导体的要求，请使用单独的保护接地电缆 (6a) 或带有单独保护接地导体的电缆 (6b)。如果保护接地导体的面积不足 10mm^2 ，那么您必须再使用一个接地导体。请参阅硬件手册了解更多信息。
 - 机架 R3: 连接输入电源电缆的附加保护接地导体。
 - 将电机电缆的相导体连接到 T1/U、T2/V 和 T3/W 端子，将输入电缆的相导体连接到 L1、L2 和 L3 端子。
7. 对于大于 -040A-x 的 R6 型机架: 在护罩中切割搭扣，以便安装电缆。机架 R8: 如果已将侧板拆下，则将其装回。在护罩上打孔，以便安装输入电缆。请参阅第 139 页的图 ...F (R6, R8)...
8. 机架 R6 和 R8: 将护罩安装在电源电缆端子上。请参阅第 139 页的图 ...F (R6, R8)...
9. 以机械方式将电缆固定在变频器外。

G – 连接控制电缆

程序:

1. 拆下前盖（如果尚未拆下）。
2. 机架 R3: 将控制盘支架提起。请参阅第 139 页的图 G (R3)...
3. 在橡胶索环上切一个适当大小的孔，然后将索环套到电缆上。将电缆从底板的孔中穿过并将索环固定到孔上。
4. 敷设电缆。机架 R3: 请参阅第 139 页的图 ...G (R3)…。
机架 R6: 请参阅第 139 页的图 ...G (R6)…。机架 R8: 请参阅第 140 页的图 ...G (R8)...
5. 使电缆的外屏蔽层在接地夹下 360 度接地。靠近控制电路板端子的电缆的剥开部分要尽可能少。
6. 以机械方式将电缆固定在变频器内。

7. **机架 R3:** 将成对电缆屏蔽层和接地线在变频器端保持未连接状态，并在电缆的另一端将它们接地。切掉变频器端未连接的任何电线。**机架 R6 和 R8:** 使成对电缆屏蔽层和接地线在控制单元下方接地夹的下面接地。
8. 将导体连接到控制单元的适当端子上。请参阅第 134 页的 [默认 IO 接线图](#)。
9. 如果交付的货物中包括选装模块，则为其连接电线。请参阅选装模块的用户手册或安装指南。
10. 以机械方式将电缆固定在变频器外。

注意:

- 将控制电缆屏蔽层的另一端保持未连接状态。
- 将信号线对双绞线尽可能靠近端子。

H – 装回盖板

请参阅第 140 页的图 [H \(R3, R6, R8\)...](#)。

默认 IO 接线图

电缆规格：
0.5 ... 2.5 mm²
(24... 14 AWG)
拧紧扭矩：
0.5 N·m
(0.4 lbf·ft) 适用于
绞合以及实心
接线。

XPOW 外部电源输入		
1	+24VI	24 V DC, 2 A
2	GND	
XAI 参考电压和模拟输入		
1	+VREF	10 V DC, R_L 1...10 kohm
2	-VREF	-10 V DC, R_L 1...10 kohm
3	AGND	地
4	AI1+	速度参考 0(2)...10 V, $R_{in} > 200$ kohm
5	AI1-	
6	AI2+	默认不使用。0(4)...20 mA, $R_{in} = 100$ ohm
7	AI2-	
J1	J1	AI1 电流/电压选择跳线
J2	J2	AI2 电流/电压选择跳线
XAO 模拟输出		
1	AO1	电机速度 rpm 0...20 mA, $R_L < 500$ ohm
2	AGND	
3	AO2	电机电流 0...20 mA, $R_L < 500$ ohm
4	AGND	
XD2D 变频器到变频器链路		
1	B	变频器到变频器链路
2	A	
3	BGND	
J3	J3	变频器到变频器链路终端开关。
XRO1、XRO2、XRO3 继电器输出		
11	NC	就绪 250 VAC / 30 VDC 2 A
12	COM	
13	NO	
21	NC	正在运行 250 VAC / 30 VDC 2 A
22	COM	
23	NO	
31	NC	故障 (-1) 250 VAC / 30 VDC 2 A
32	COM	
33	NO	
XD24 数字连锁		
1	DIIL	运行使能
2	+24VD	+24 V DC 200 mA
3	DICOM	数字输入接地
4	+24VD	+24 V DC 200 mA
5	DIOGND	数字输入/输出接地
J6		接地选择开关
XDIO 数字输入/输出		
1	DIO1	输出：就绪
2	DIO2	输出：正在运行
XDI 数字输入		
1	DI1	停止(0) / 启动(1)
2	DI2	正向(0) / 反向(1)
3	DI3	复位
4	DI4	加速和减速选择
5	DI5	恒定转速 1 (1 = 开启)
6	DI6	默认不使用。
XSTO 安全转矩取消		
1	OUT1	安全转矩取消。两个电路都必须闭合后方可启动电机。
2	SGND	
3	IN1	
4	IN2	
X12	安全功能模块连接	
X13	控制盘连接	
X205	记忆单元连接	

合规性声明 (EU)

Power and productivity
for a better world™



EU Declaration of Conformity

Machinery Directive 2006/42/EC

We

Manufacturer: ABB Oy
Address: Hiomotie 13, 00380 Helsinki, Finland.
Phone: +358 10 22 11

declare under our sole responsibility that the following products:

Frequency converters

ACS880-01

ACS880-04/-04F

ACS880-M04

ACS880-11/-31/-14/-34

with regard to the built-in safety function:

Safe torque off;

and with regard to the following optional safety functions with FSO-12 module (option code +Q973, encoderless):

Safe stop 1; Safe stop emergency; Safely-limited speed; Safe maximum speed; Safe brake control; Prevention of Unexpected Start-up;

and with regard to the following optional safety functions (option codes +Q972 and +L521, encoder supported):

Safe stop 1; Safe stop emergency; Safely-limited speed; Safe maximum speed; Safe brake control; Safe speed monitor; Safe direction; Prevention of Unexpected Start-up;

and with regard to the following optional safety function with FPTC-01 thermistor protection module (option code +L536):

Safe Motor Temperature;

are in conformity with all the relevant safety component requirements of EU Machinery Directive 2006/42/EC, when the listed safety functions are used for safety component functionality.

Power and productivity
for a better world™



EU Declaration of Conformity

Machinery Directive 2006/42/EC

The following harmonized standards have been applied:

EN 61800-5-2:2007	<i>Adjustable speed electrical power drive systems – Part 5-2: Safety requirements - Functional</i>
EN 62061:2005 + AC:2010 + A1:2013 + A2:2015	<i>Safety of machinery – Functional safety of safety-related electrical, electronic and programmable electronic control systems</i>
EN ISO 13849-1:2015	<i>Safety of machinery – Safety-related parts of control systems. Part 1: General requirements</i>
EN ISO 13849-2:2012	<i>Safety of machinery – Safety-related parts of the control systems. Part 2: Validation</i>
EN 60204-1: 2006 + A1:2009 + AC:2010	<i>Safety of machinery – Electrical equipment of machines – Part 1: General requirements</i>

The following other standards have been applied:

IEC 61508:2010	<i>Functional safety of electrical / electronic / programmable electronic safety-related systems</i>
IEC 61800-5-2:2016	<i>Adjustable speed electrical power drive systems – Part 5-2: Safety requirements - Functional</i>

The products referred in this Declaration of conformity fulfil the relevant provisions of other European Union Directives which are notified in Single EU Declaration of conformity 3AXD10000497831.

Person authorized to compile the technical file:

Name and address: Juha Martinmaa, Hiomotie 13, 00380 Helsinki, Finland.

Helsinki, 15 Sep 2017

Manufacturer representative:

Vesa Kandell
Vice President, ABB Oy

Figures

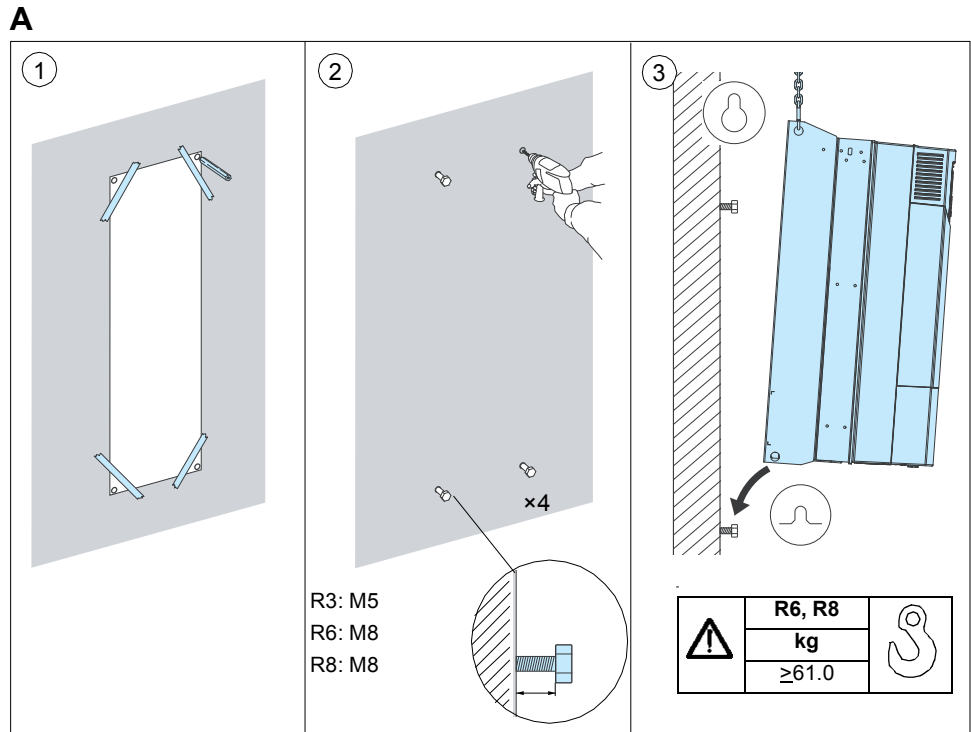

B (R6, R8)...

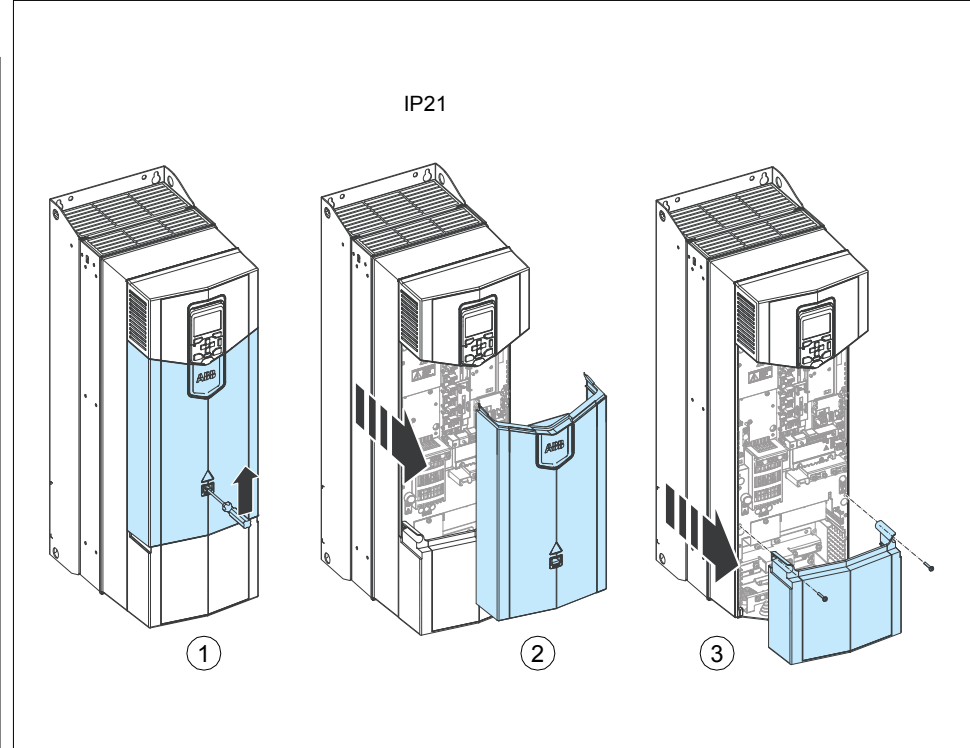

C

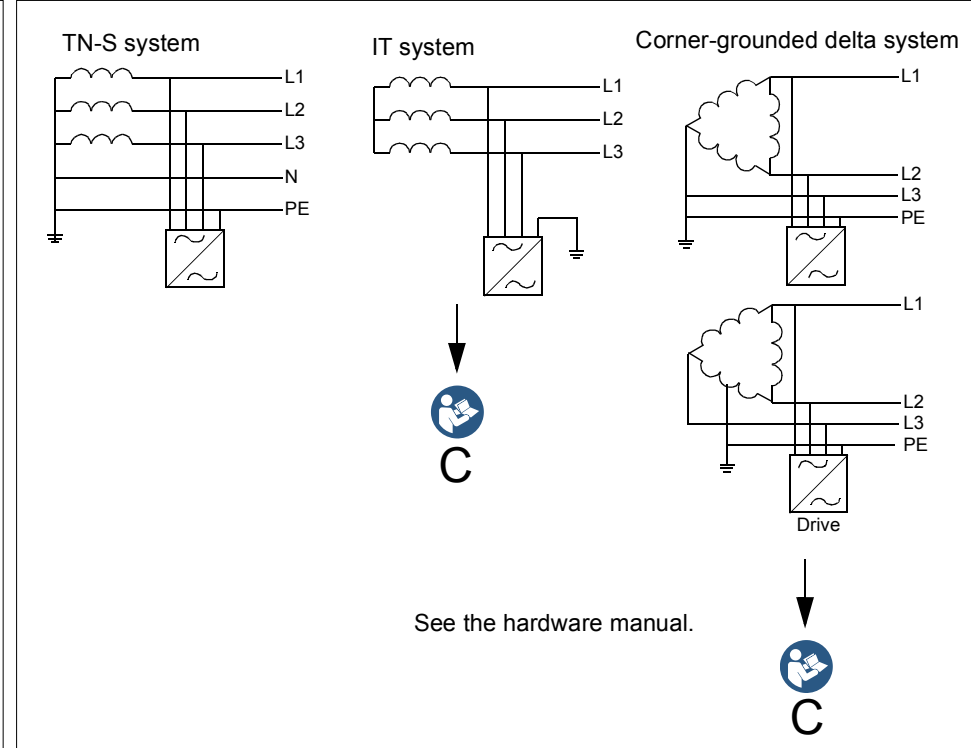

B (R3)

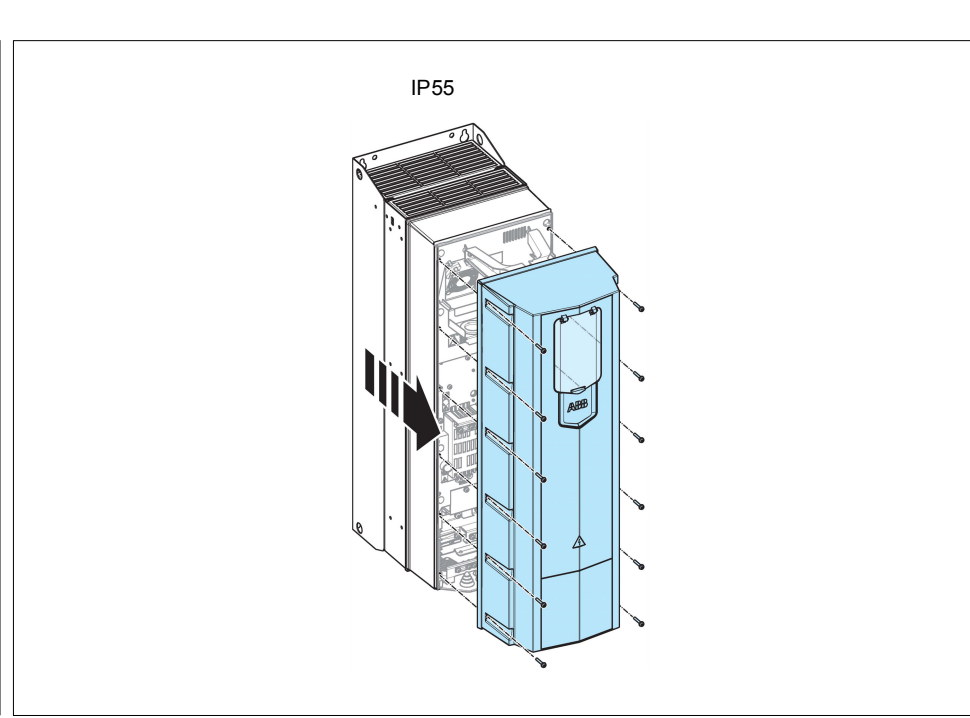
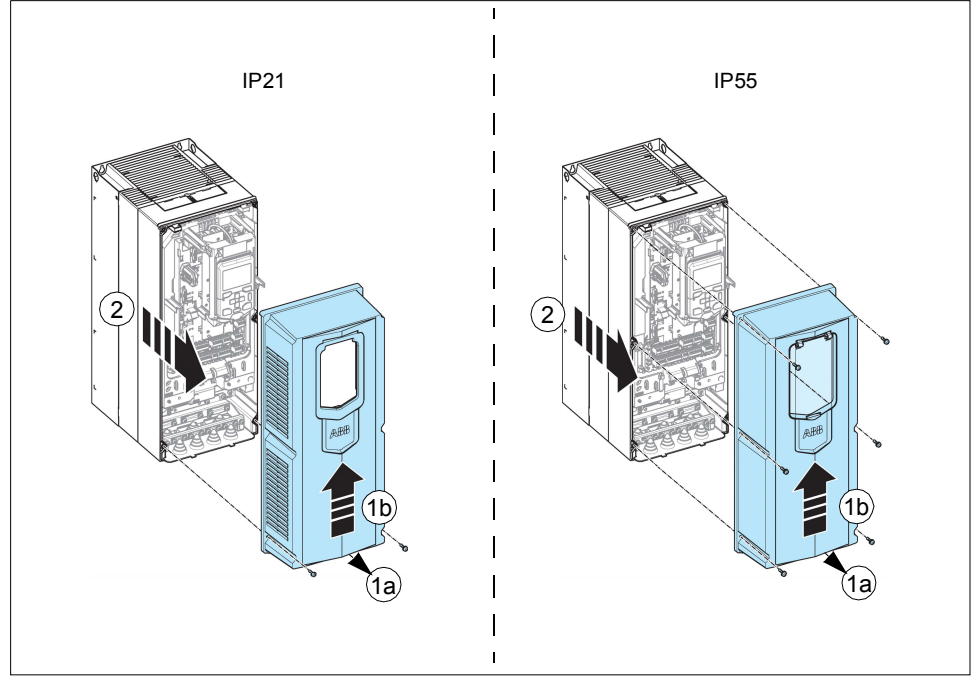

D

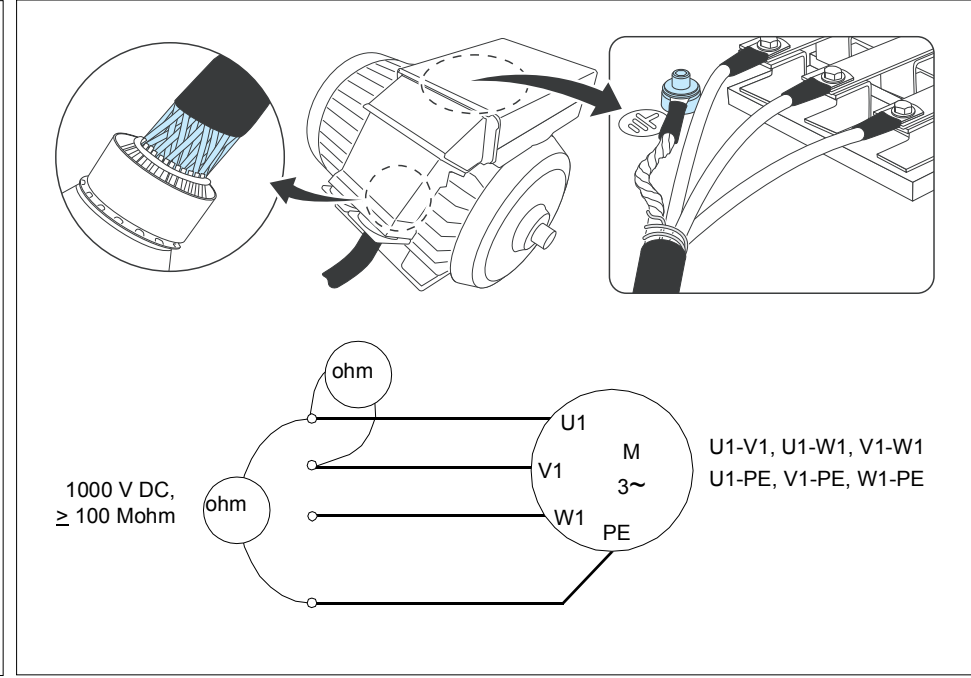

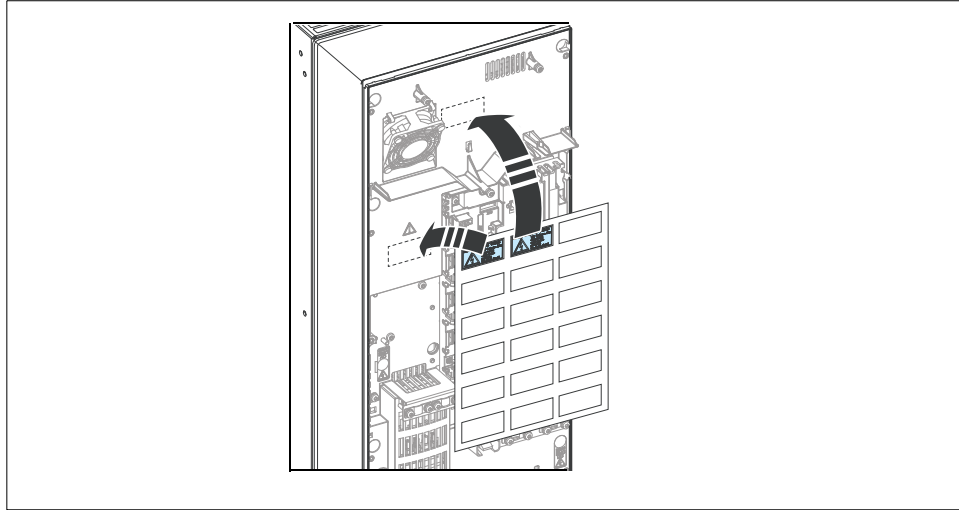

F (R6, R8)...

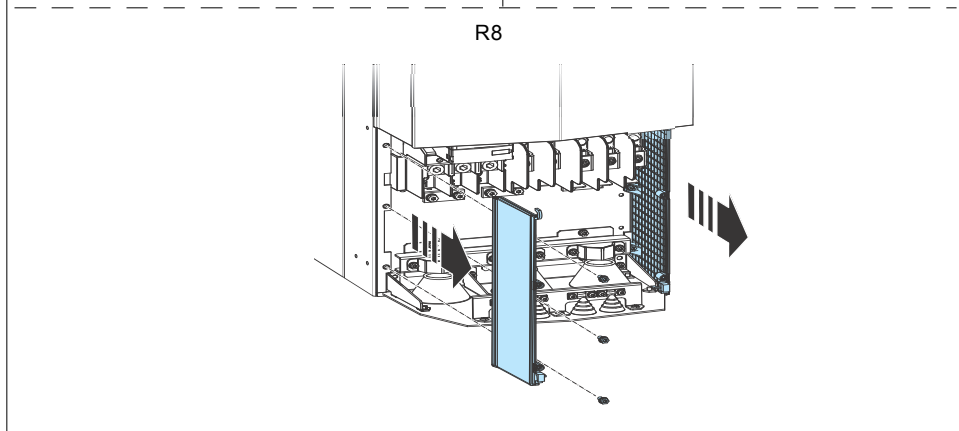
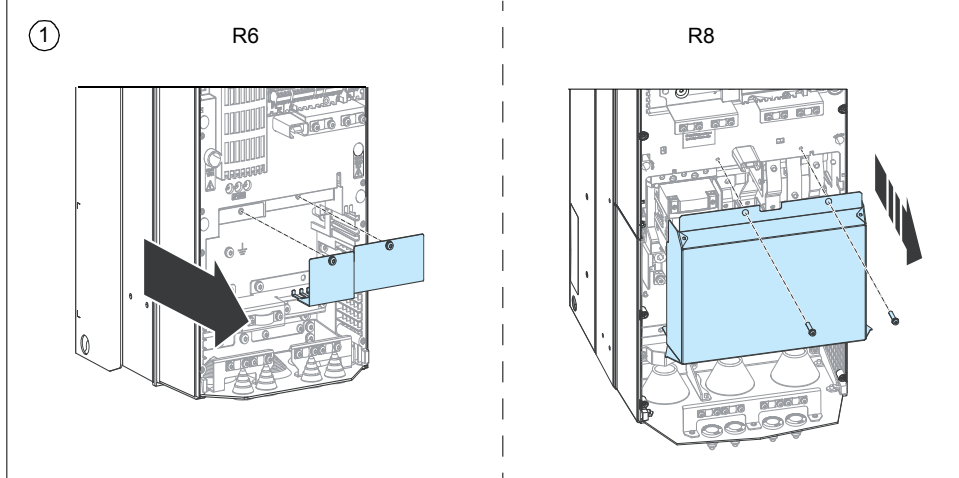

...F...

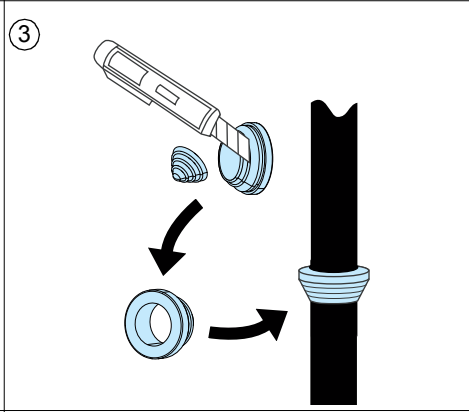
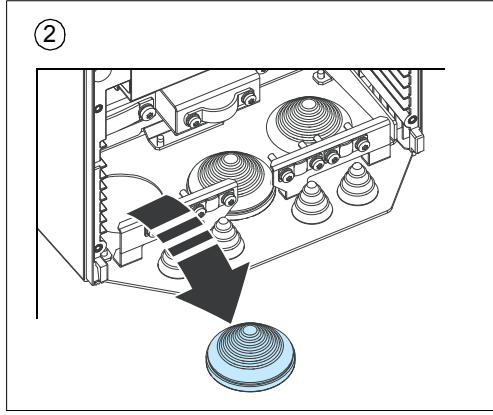

...F...

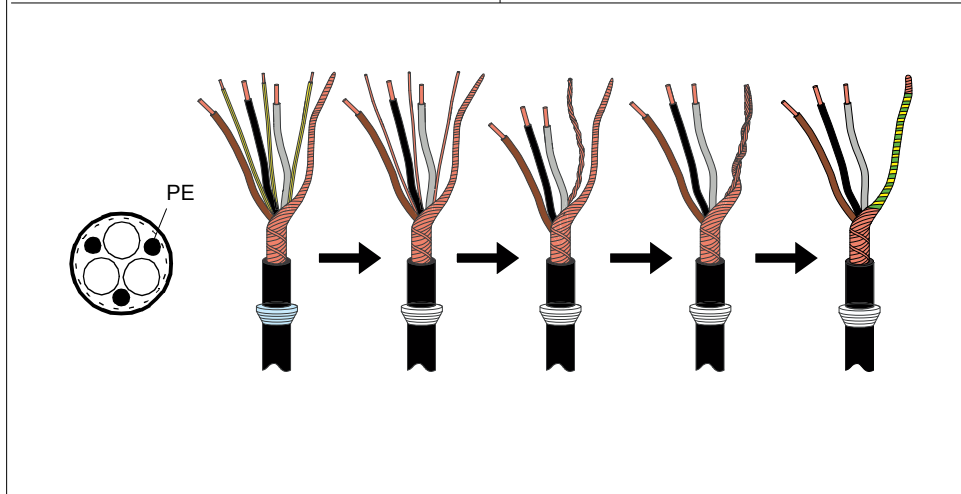
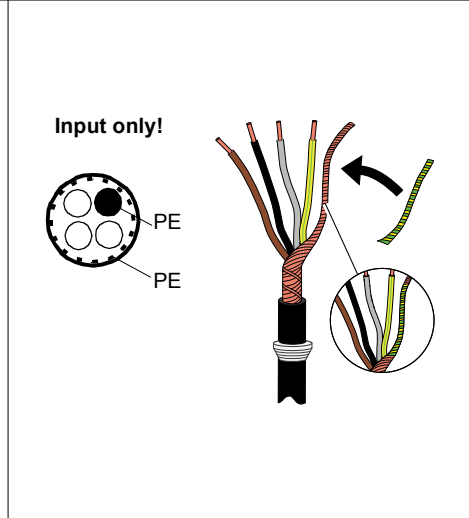
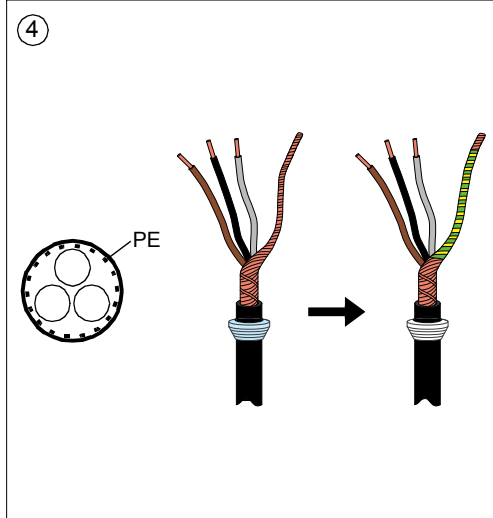

...F...

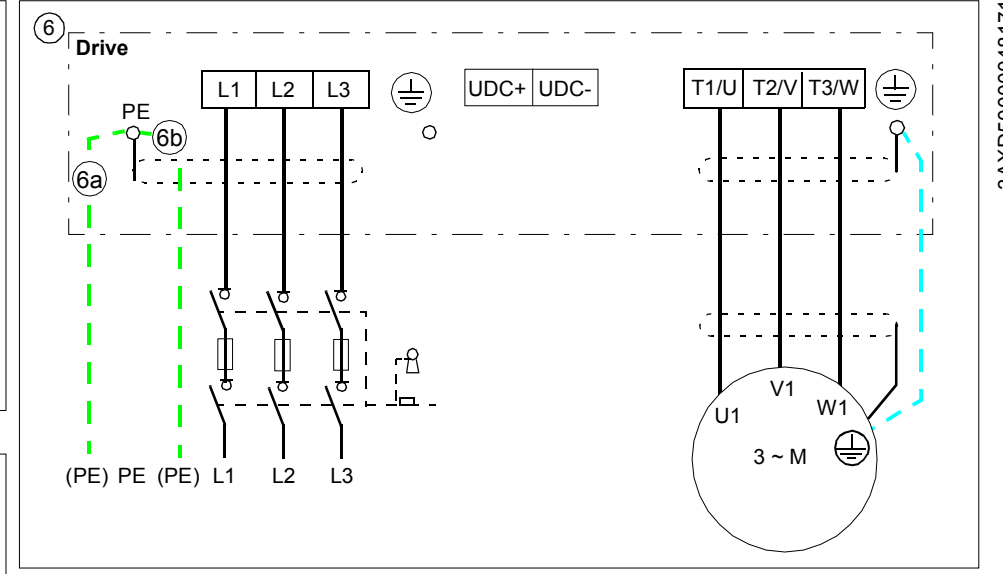

...F (R3)...

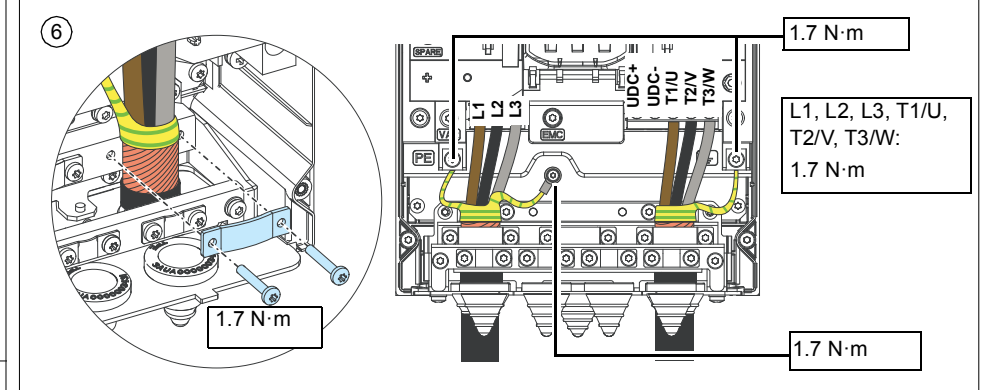

...F (R6)...

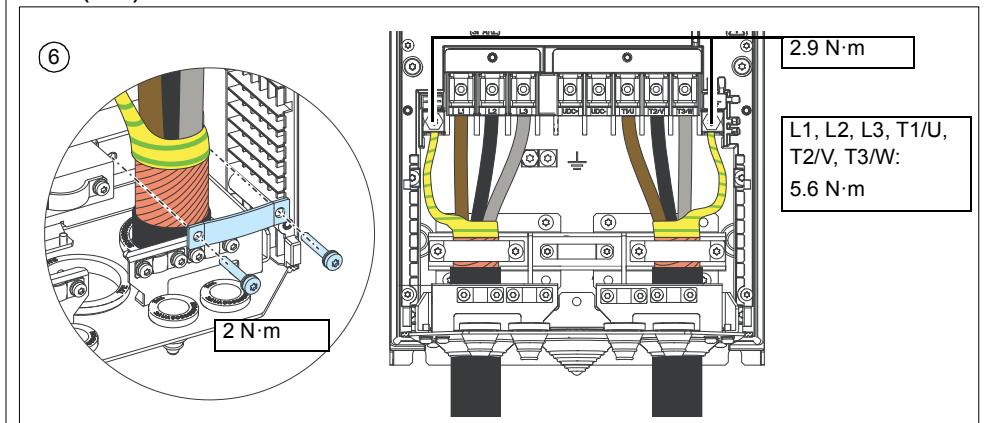

...F (R8)...

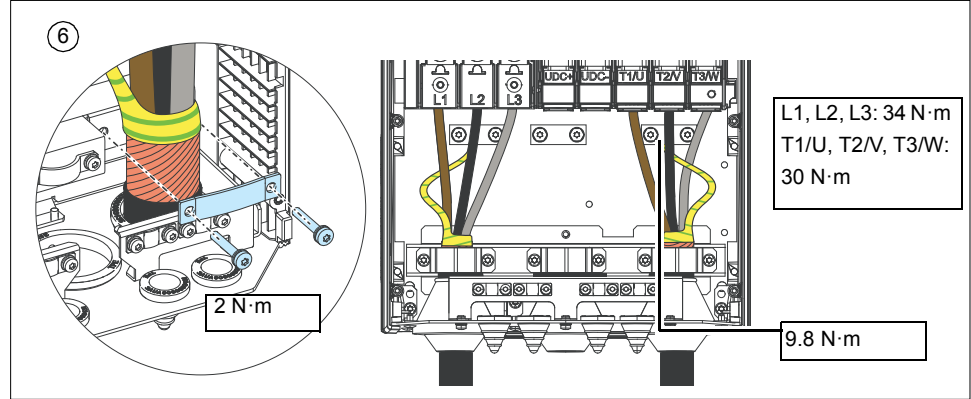

...F (R6, R8)...

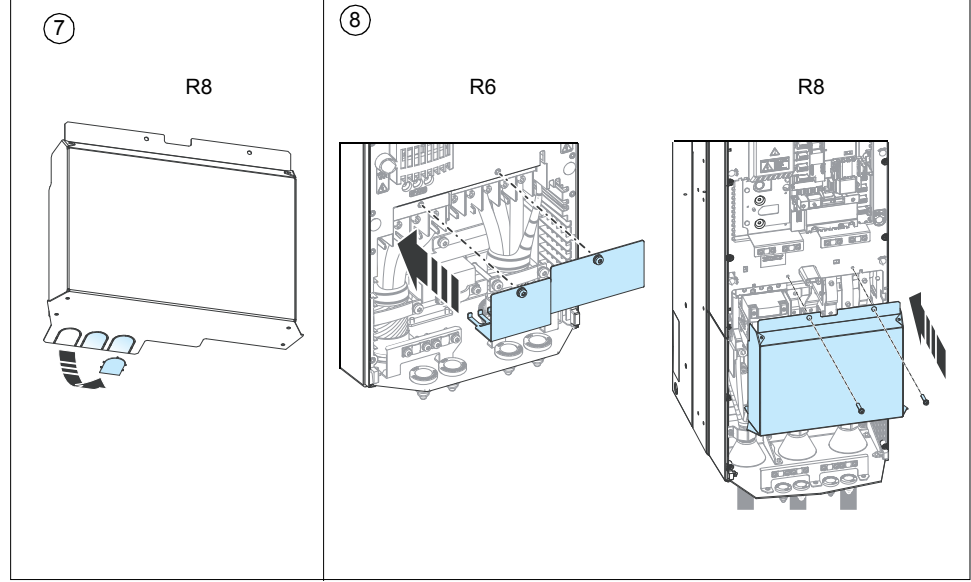

G (R3)...

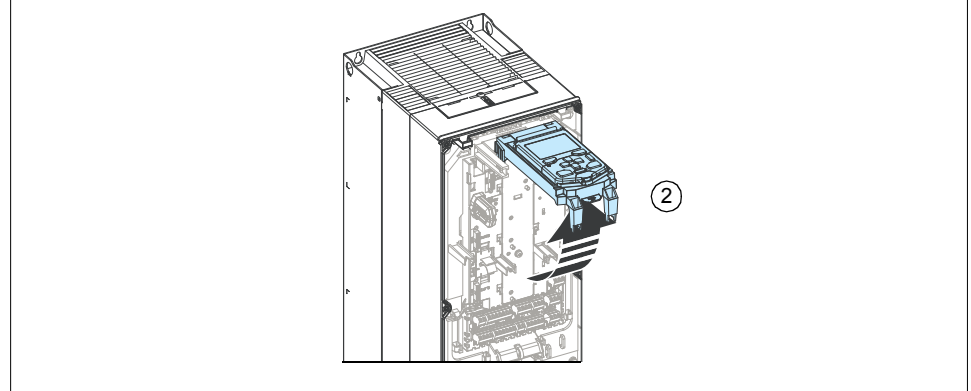

...G (R3)...

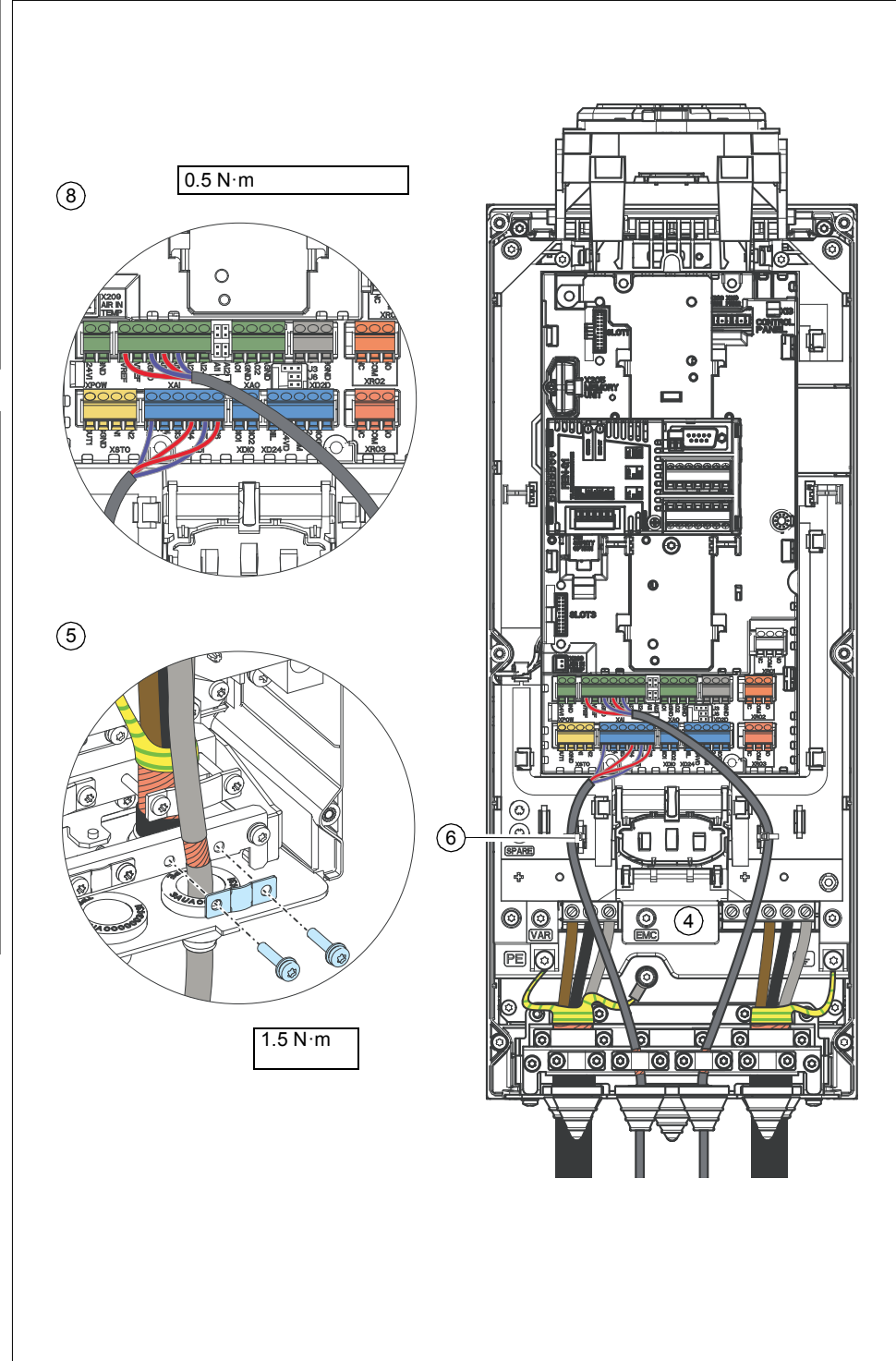

...G (R6)...

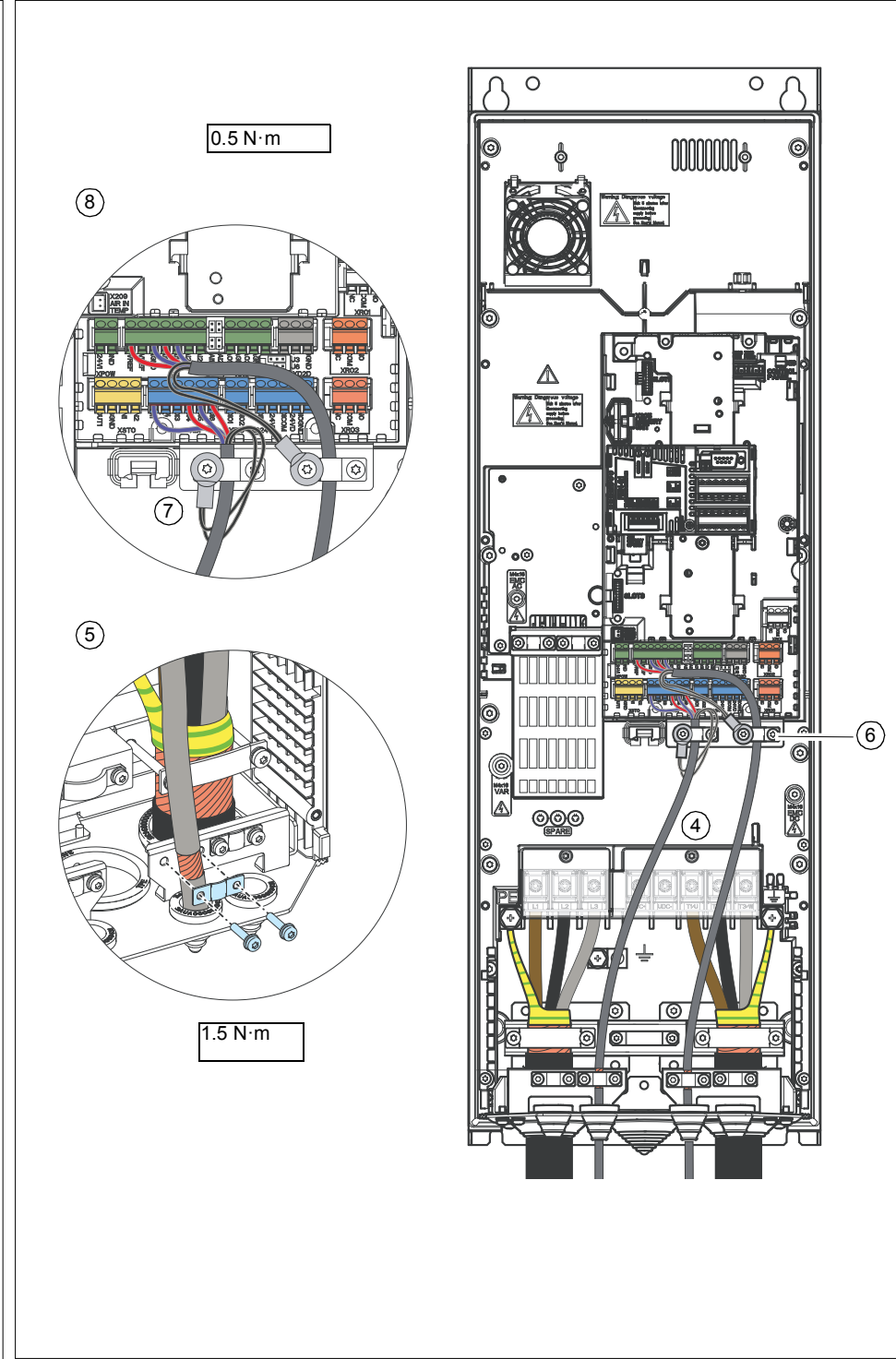

...G (R8)...

0.5...0.6 N·m

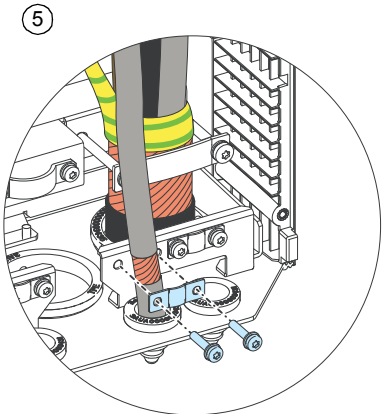
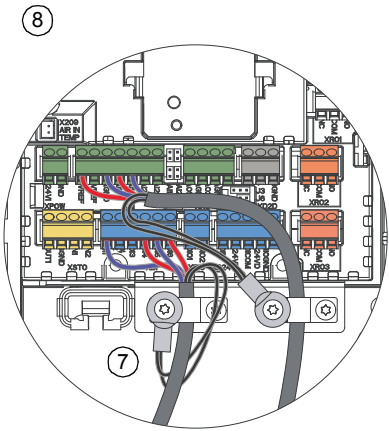

1.5 N·m

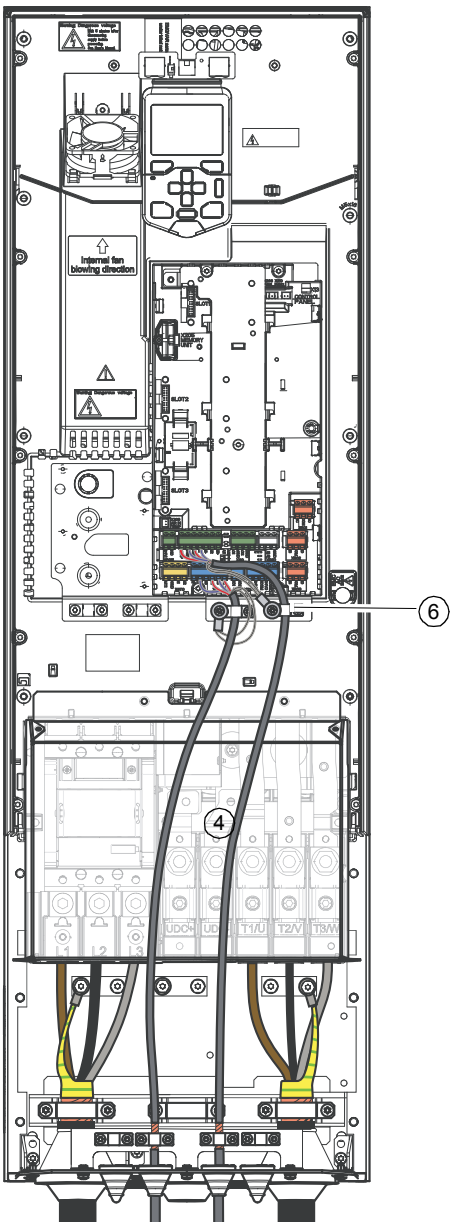

...G

Wire sizes:
0.5 ... 2.5 mm²
Tightening
torques: 0.5 N·m
for both
stranded and
solid wiring.

XPOW External power input	
1	+24VI 24 V DC, 2 A
2	GND
XAI Reference voltage and analog inputs	
1	+VREF 10 V DC, R _I 1...10 kohm
2	-VREF -10 V DC, R _I 1...10 kohm
3	AGND Ground
4	AI1+ Speed reference 0(2)...10 V, R _{Iin} > 200 kohm
5	AI1-
6	AI2+ By default not in use. 0(4)...20 mA, R _{Iin} = 100 ohm
7	AI2-
J1	J1 AI1 current/voltage selection jumper
J2	J2 AI2 current/voltage selection jumper
XAO Analog outputs	
1	AO1 Motor speed rpm 0...20 mA, R _L < 500 ohm
2	AGND
3	AO2 Motor current 0...20 mA, R _L < 500 ohm
4	AGND
XD2D Drive-to-drive link	
1	B Drive-to-drive link
2	A Drive-to-drive link
3	BGND
J3	J3 Drive-to-drive link termination switch
XRO1, XRO2, XRO3 Relay outputs	
11	NC Ready 250 V AC / 30 V DC 2 A
12	COM
13	NO
21	NC Running 250 V AC / 30 V DC 2 A
22	COM
23	NO
31	NC Faulted(-1) 250 V AC / 30 V DC 2 A
32	COM
33	NO
XD24 Digital interlock	
1	DIIL Run enable
2	+24VD +24 V DC 200 mA
3	DICOM Digital input ground
4	+24VD +24 V DC 200 mA
5	DIOGND Digital input/output ground
J6	J6 Ground selection switch
XDIO Digital input/outputs	
1	DIO1 Output: Ready
2	DIO2 Output: Running
XDI Digital inputs	
1	DI1 Stop (0) / Start (1)
2	DI2 Forward (0) / Reverse (1)
3	DI3 Reset
4	DI4 Acceleration & deceleration select
5	DI5 Constant speed 1 (1 = On)
6	DI6 By default not in use.
XSTO Safe torque off	
1	OUT1
2	SGND
3	IN1
4	IN2
X12	Safety functions module connection
X13	Control panel connection
X205	Memory unit connection

H (R3, R6, R8)...

R3 IP21

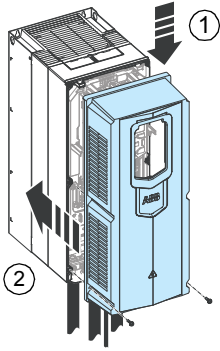

2 N·m

R3 IP55

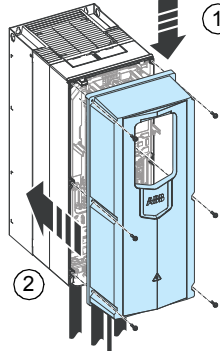

R6, R8 IP21

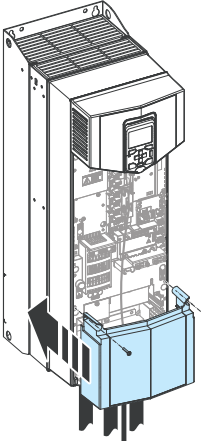

2 N·m

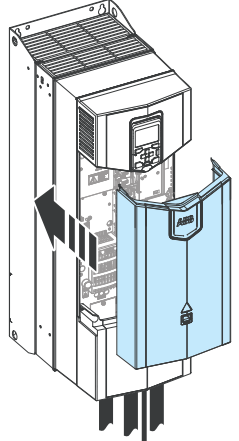

R6, R8 IP55

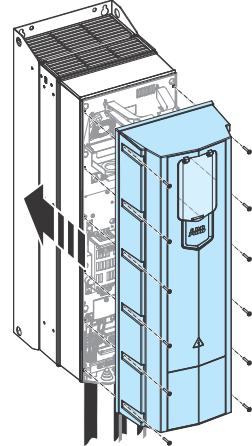

2 N·m

Figures USA



A

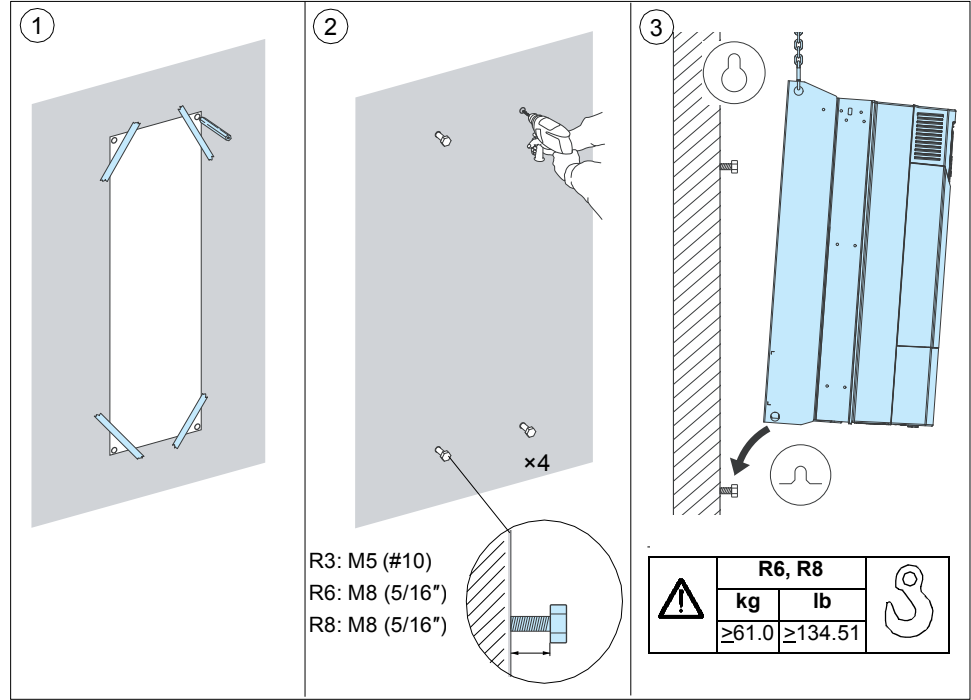

B (R3)

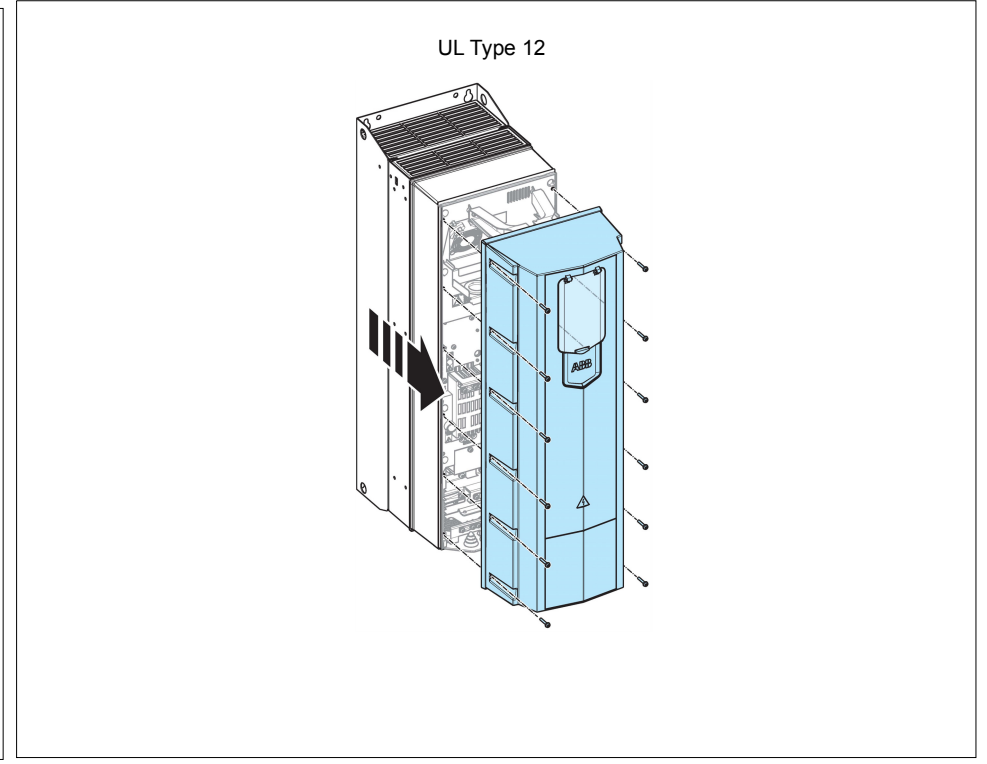
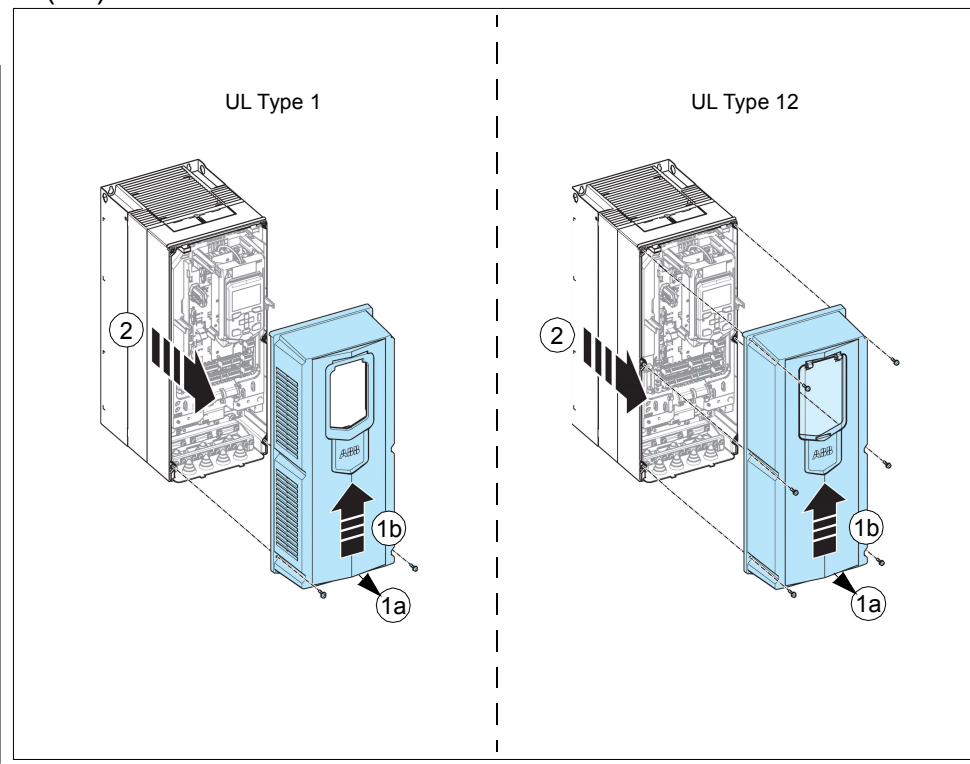

A (R6, R8)

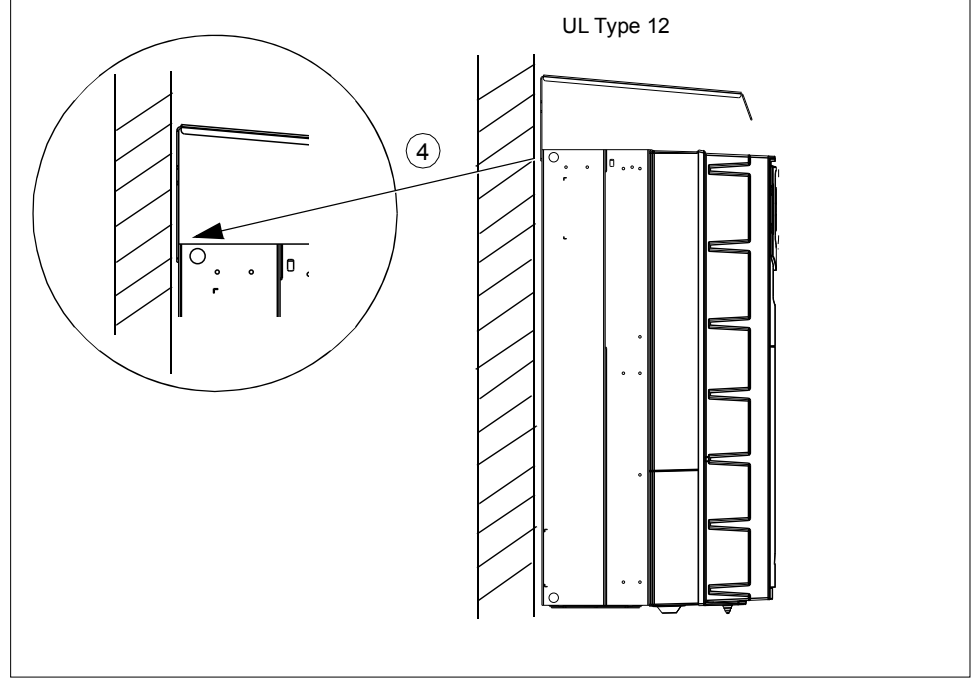

B (R6, R8)...

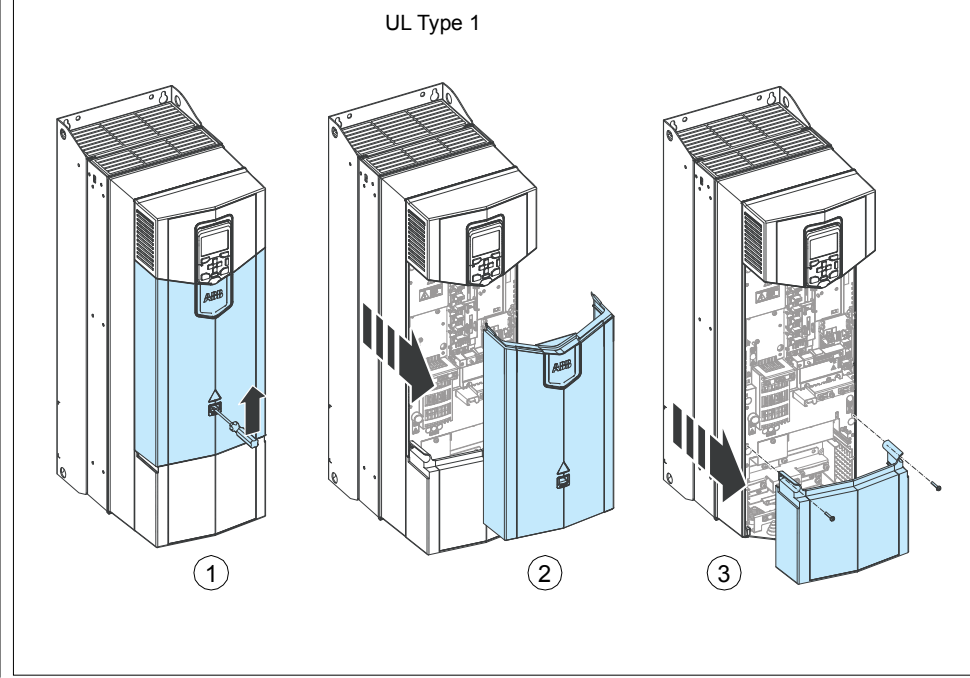

C

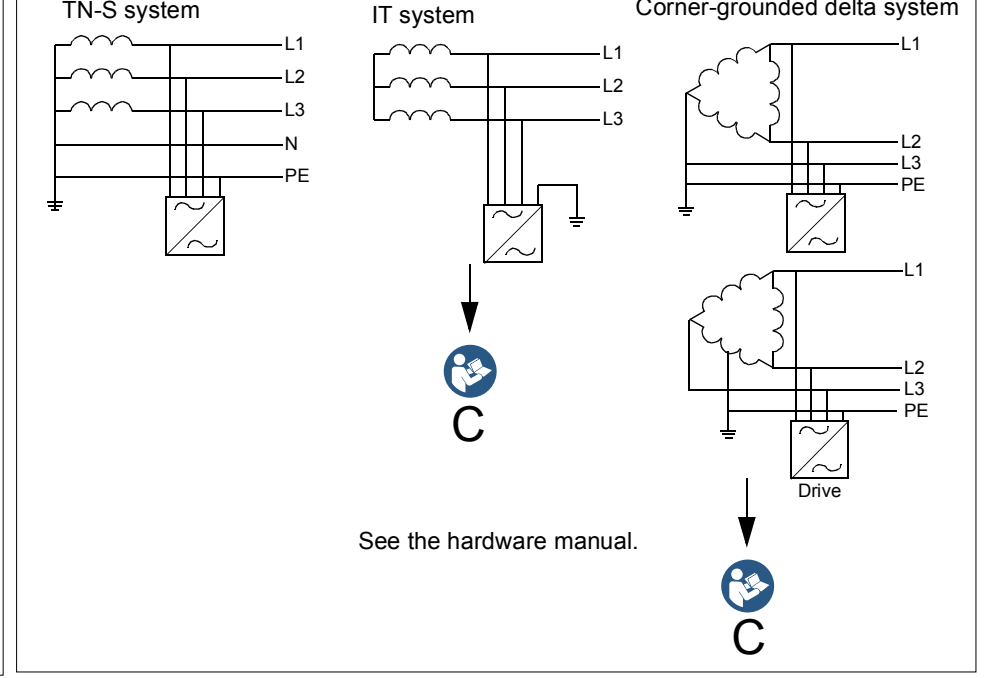

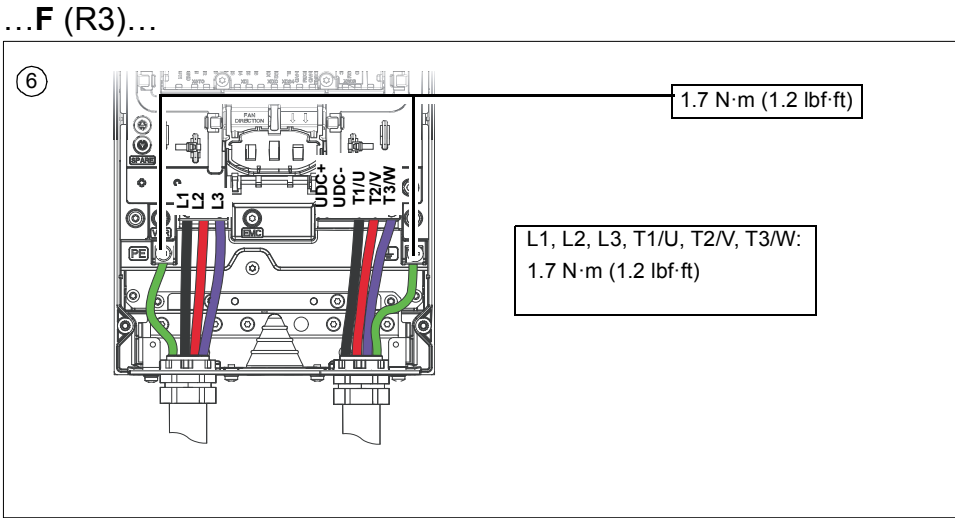
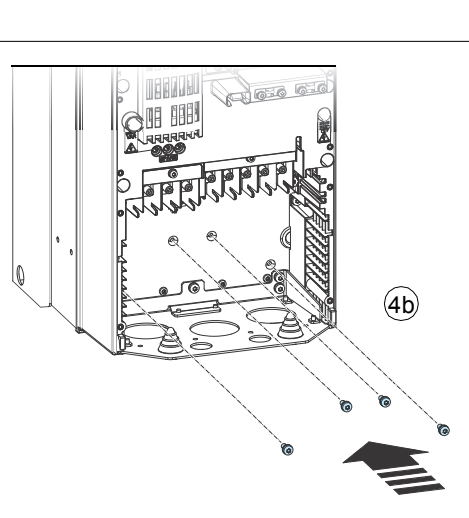
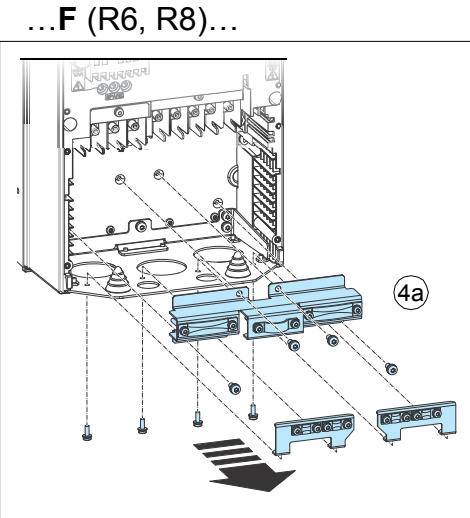
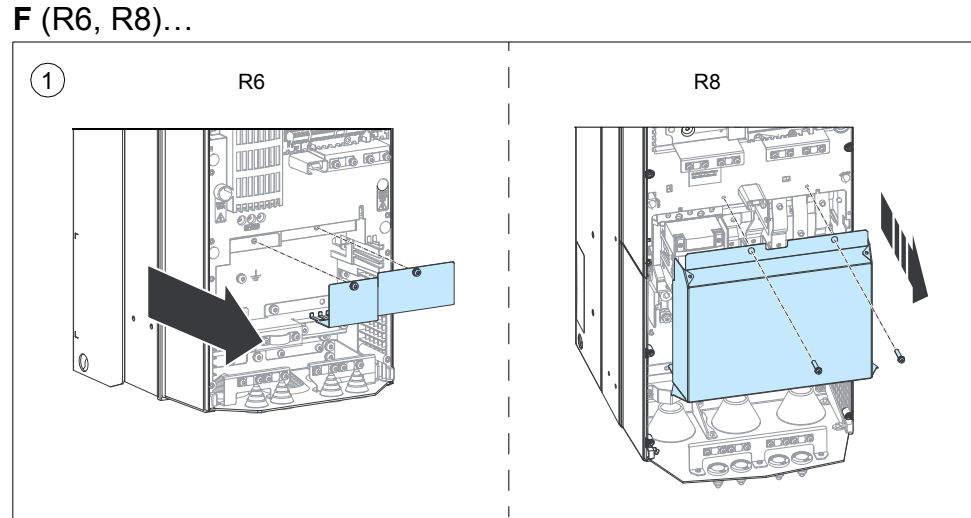
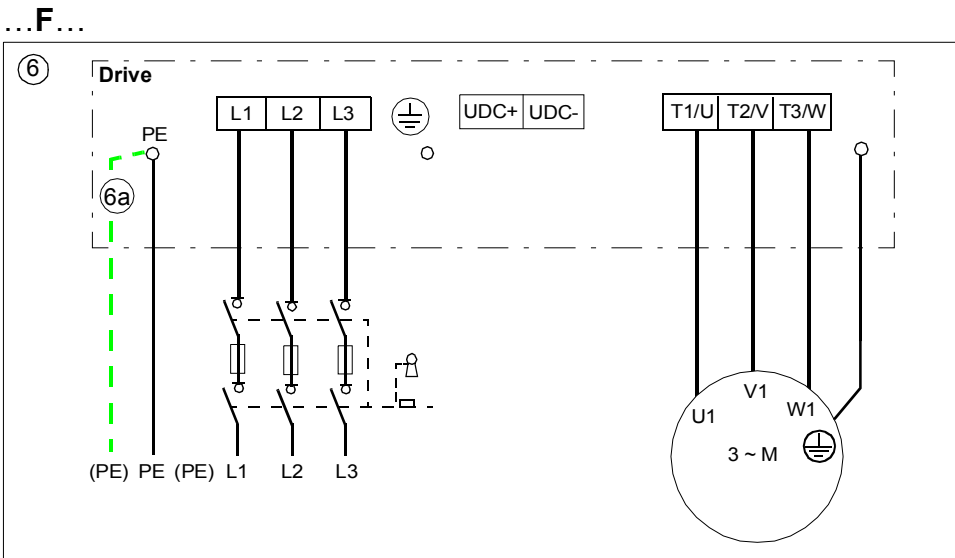
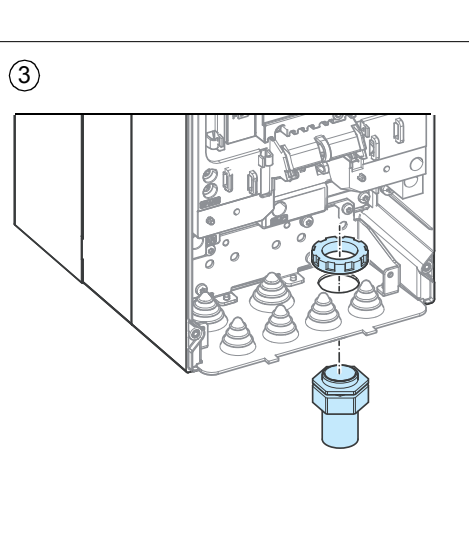
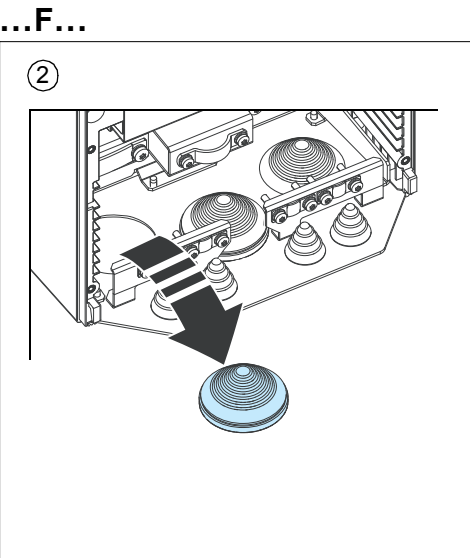
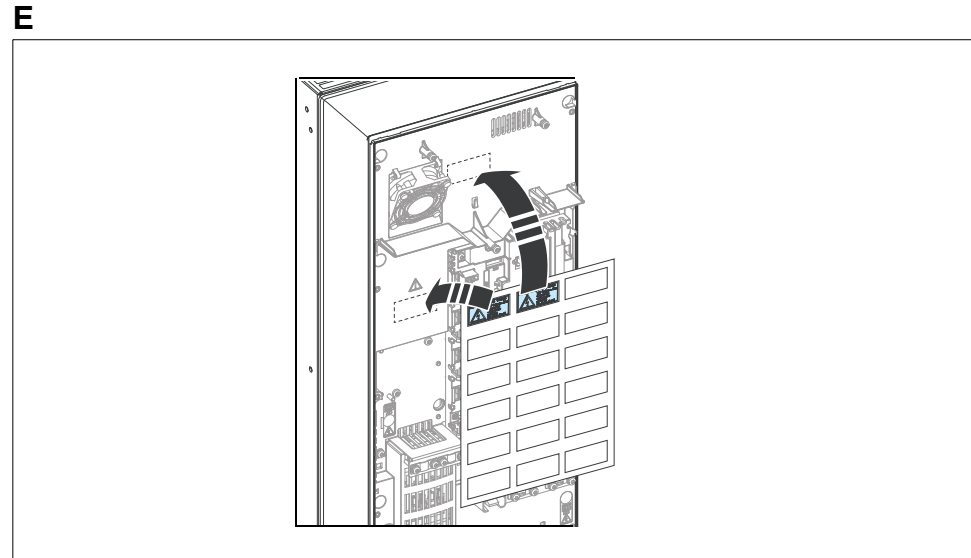
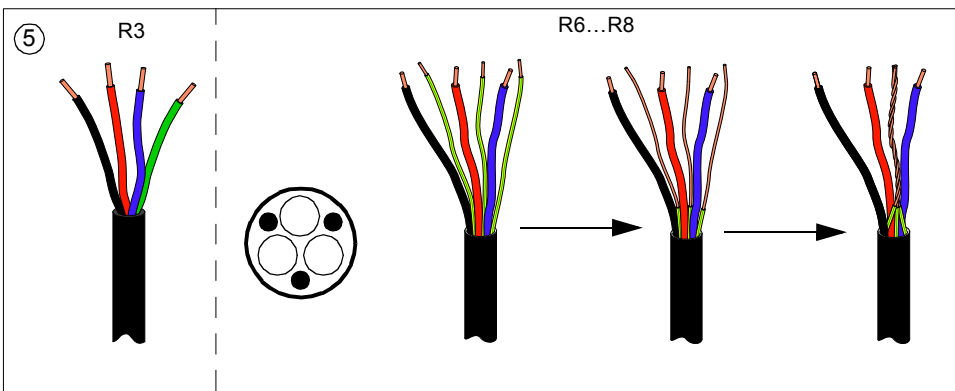
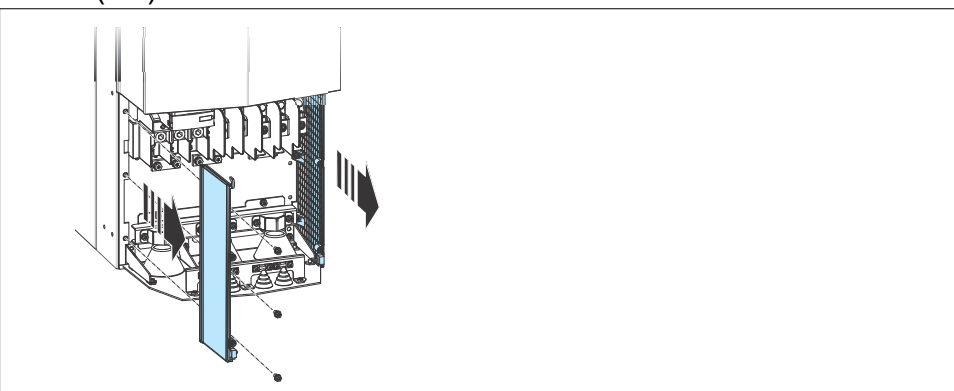
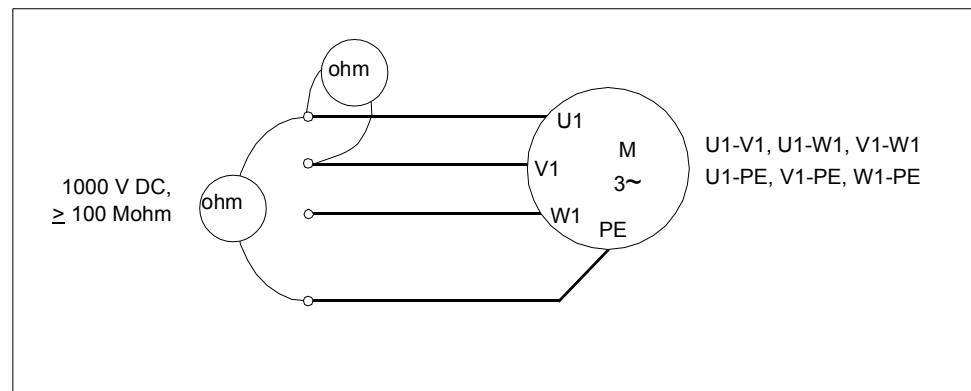

...F (R6)...

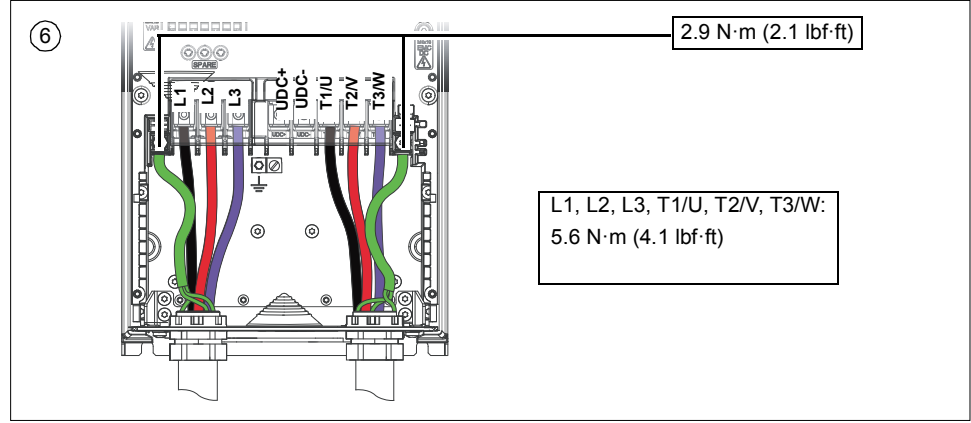

...F (R6, R8)...

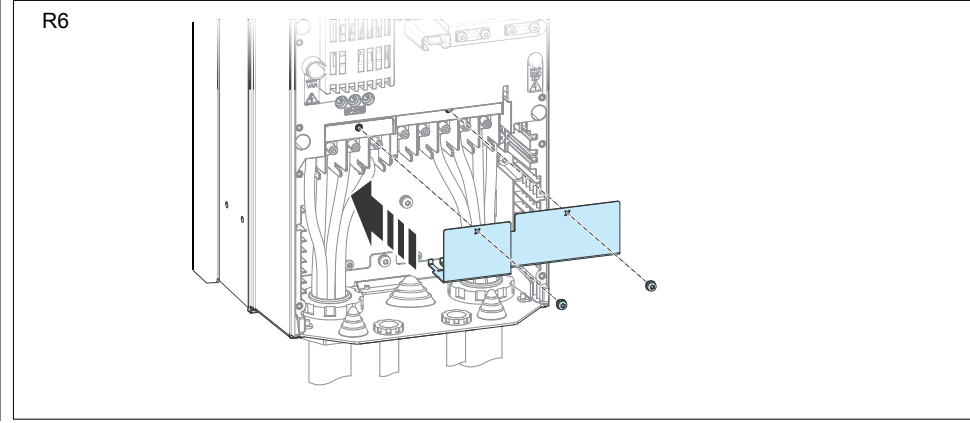

...F (R8).....

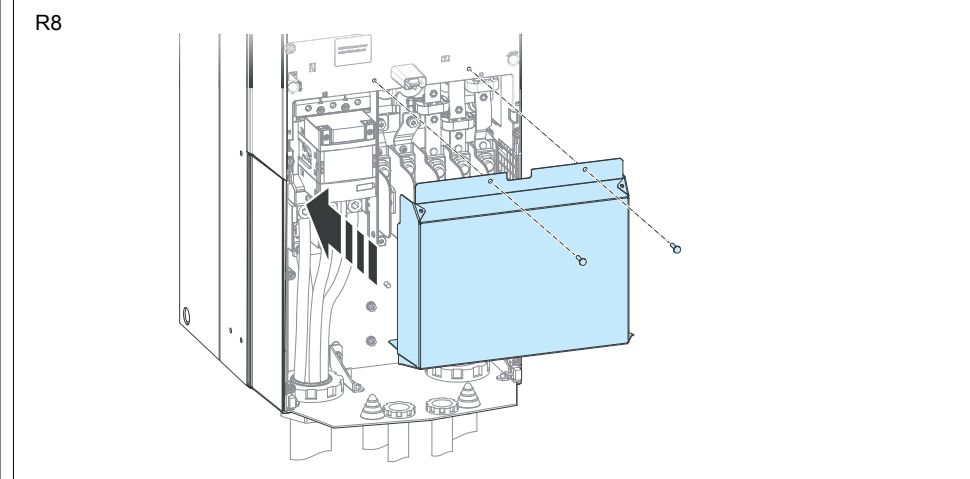
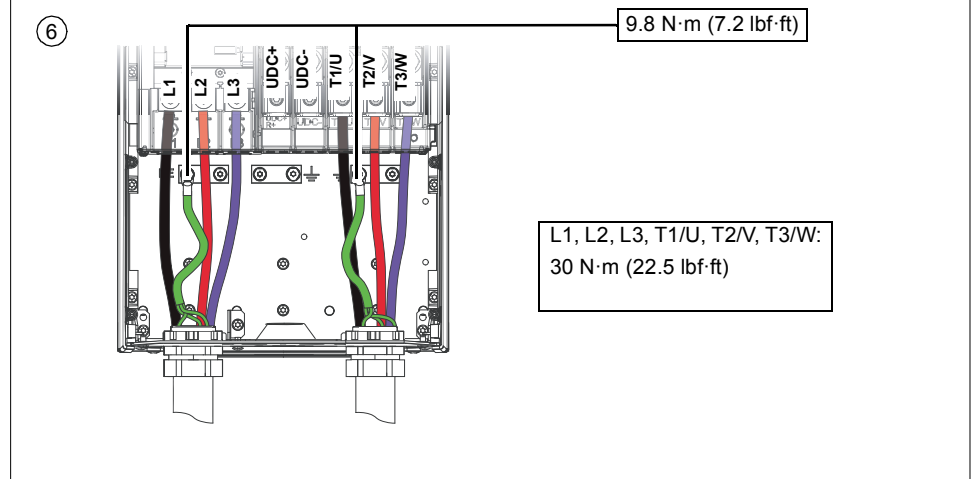

F (R8)...

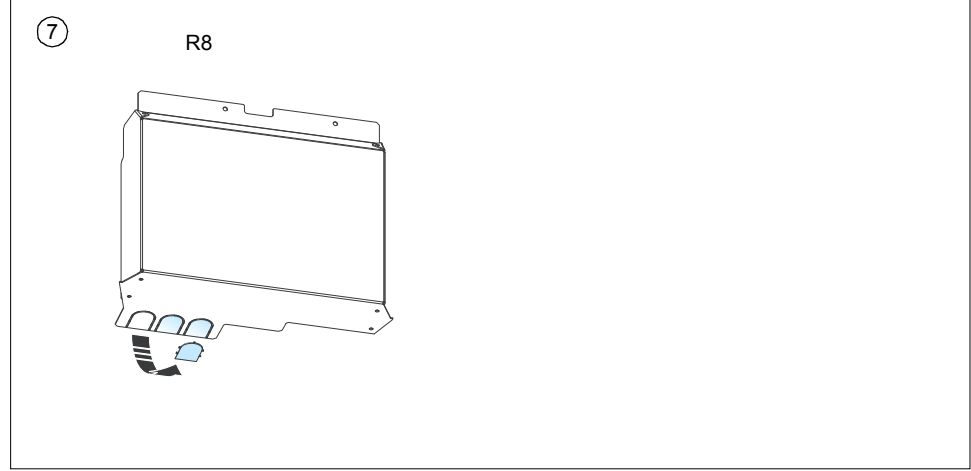

G (R3)...

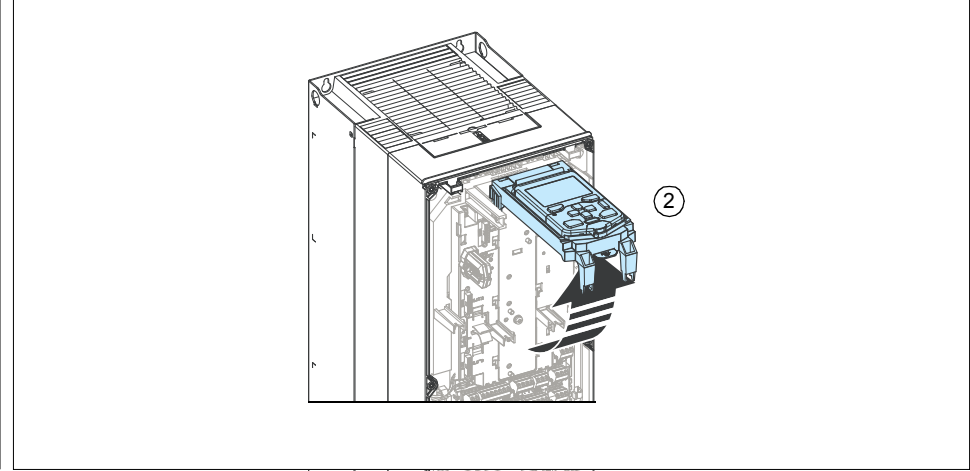

...G (R3)...

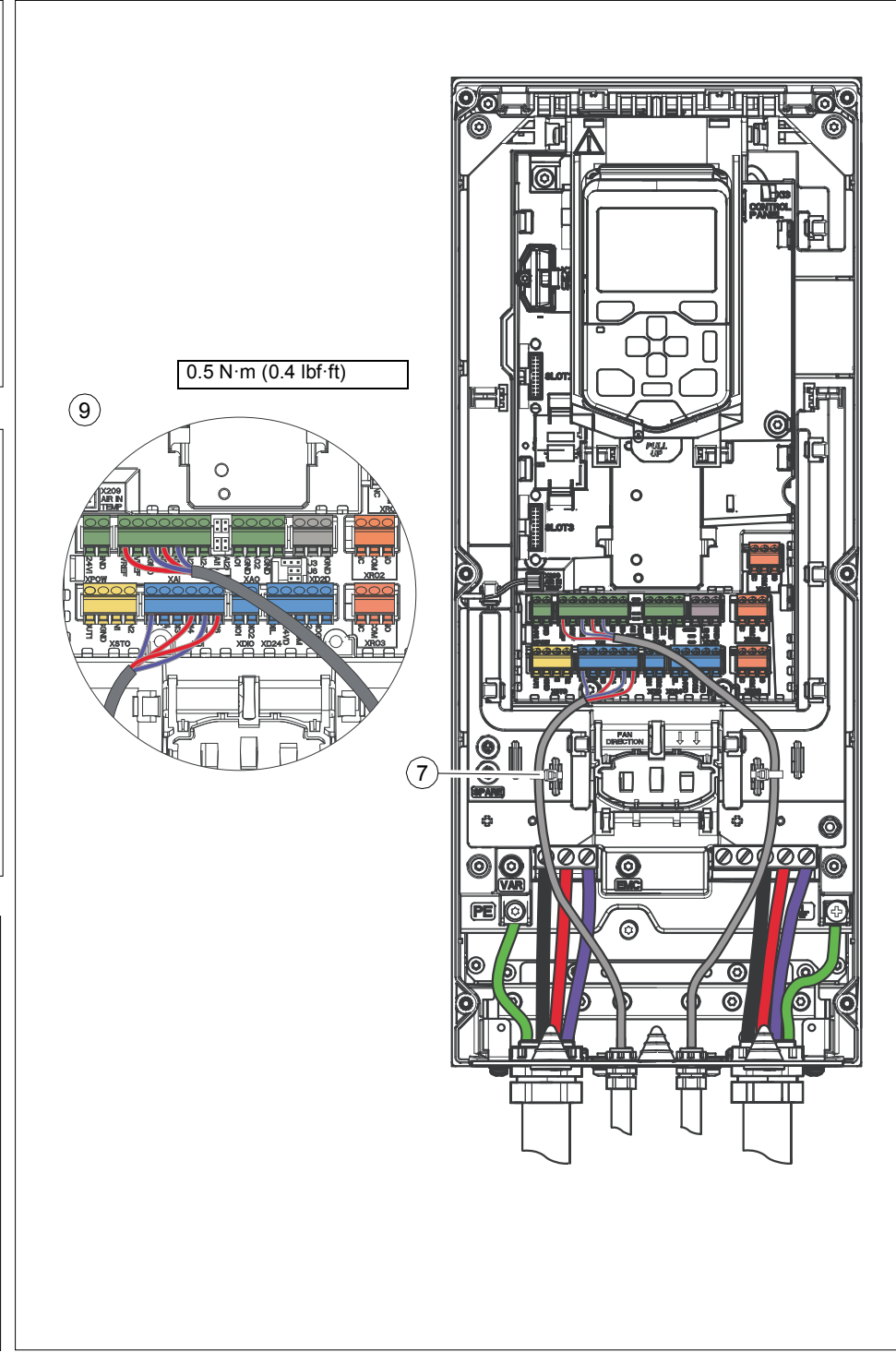

...G (R6)...

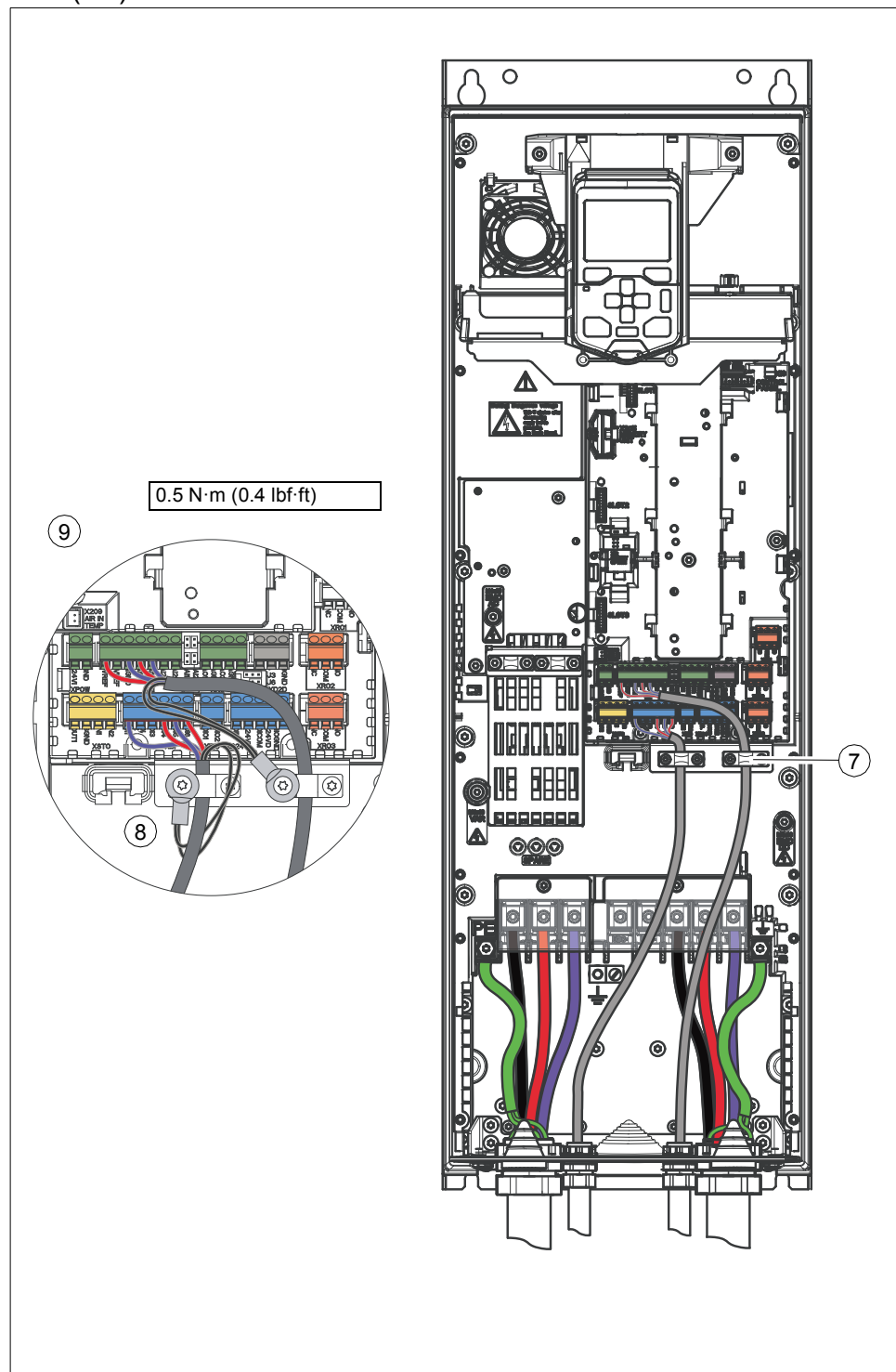

...G (R8)...

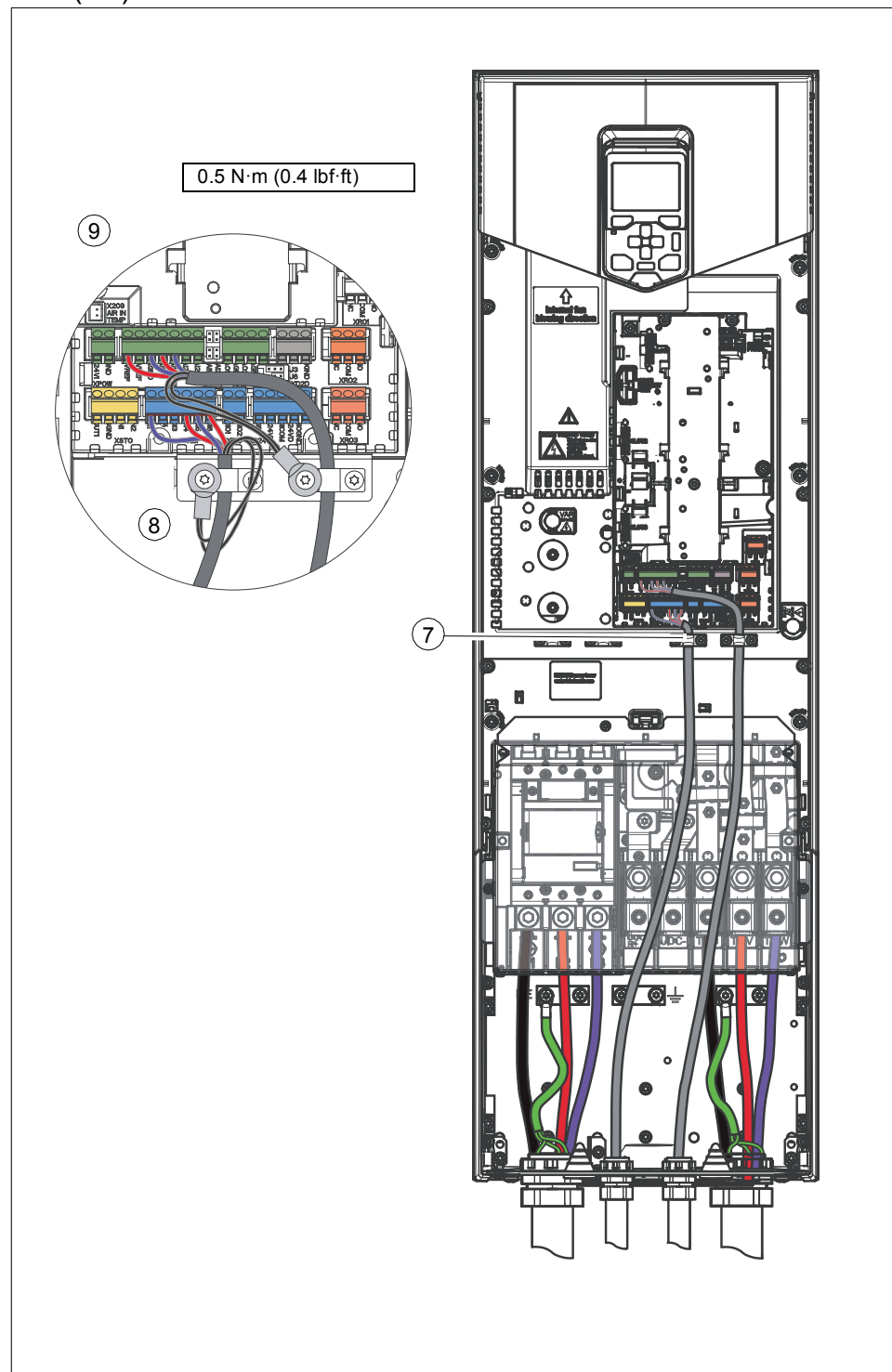

...G

Wire sizes:
0.5 ... 2.5 mm²
(24... 14 AWG)
Tightening
torques: 0.5 N·m
(0.4 lbf·ft) for
both stranded
and solid wiring.

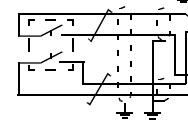
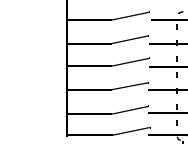
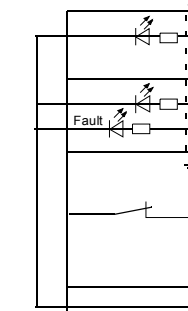
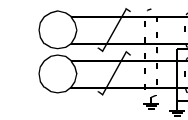
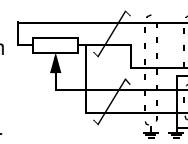

XPOW External power input		
1	+24VI	24 V DC, 2 A
2	GND	
XAI Reference voltage and analog inputs		
1	+VREF	10 V DC, R _L 1...10 kohm
2	-VREF	-10 V DC, R _L 1...10 kohm
3	AGND	Ground
4	AI1+	Speed reference 0(2)...10 V, R _{in} > 200 kohm
5	AI1-	
6	AI2+	By default not in use. 0(4)...20 mA, R _{in} = 100 ohm
7	AI2-	
J1	J1	AI1 current/voltage selection jumper
J2	J2	AI2 current/voltage selection jumper
XAO Analog outputs		
1	AO1	Motor speed rpm 0...20 mA, R _L < 500 ohm
2	AGND	
3	AO2	Motor current 0...20 mA, R _L < 500 ohm
4	AGND	
XD2D Drive-to-drive link		
1	B	
2	A	Drive-to-drive link
3	BGND	
J3	J3	Drive-to-drive link termination switch
XRO1, XRO2, XRO3 Relay outputs		
11	NC	Ready 250 V AC / 30 V DC 2 A
12	COM	
13	NO	
21	NC	Running 250 V AC / 30 V DC 2 A
22	COM	
23	NO	
31	NC	Faulted(-1) 250 V AC / 30 V DC 2 A
32	COM	
33	NO	
XD24 Digital interlock		
1	DIIL	Run enable
2	+24VD	+24 V DC 200 mA
3	DICOM	Digital input ground
4	+24VD	+24 V DC 200 mA
5	DIOGND	Digital input/output ground
J6	J6	Ground selection switch
XDIO Digital input/outputs		
1	DIO1	Output: Ready
2	DIO2	Output: Running
XDI Digital inputs		
1	DI1	Stop (0) / Start (1)
2	DI2	Forward (0) / Reverse (1)
3	DI3	Reset
4	DI4	Acceleration & deceleration select
5	DI5	Constant speed 1 (1 = On)
6	DI6	By default not in use.
XSTO Safe torque off		
1	OUT1	
2	SGND	Safe torque off. Both circuits must be closed for the drive to start.
3	IN1	
4	IN2	
X12	Safety functions module connection	
X13	Control panel connection	
X205	Memory unit connection	

H (R3, R6, R8)...

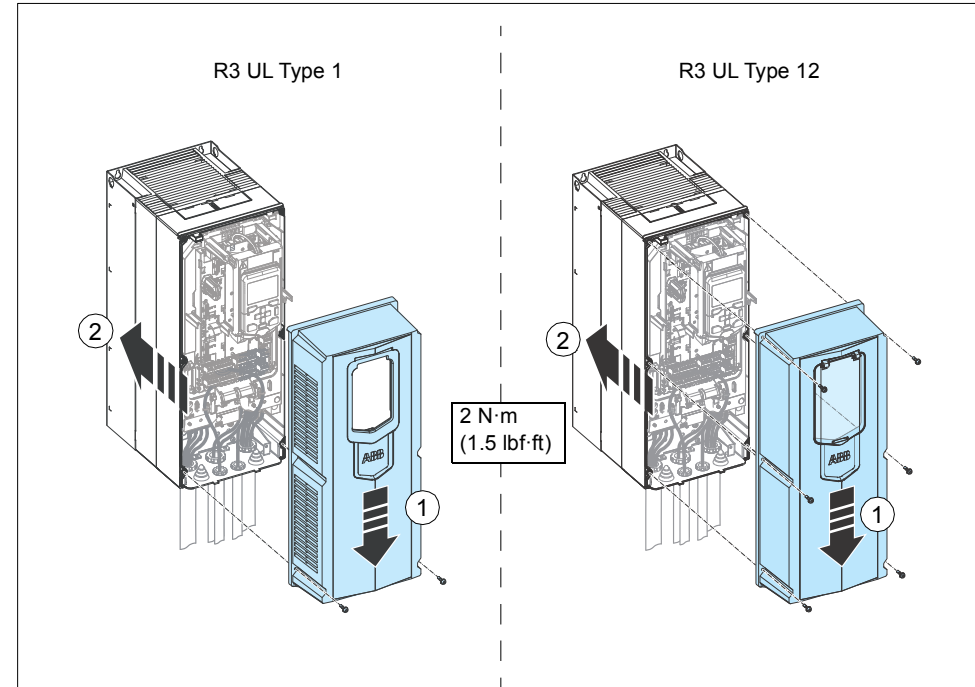

H (R8)

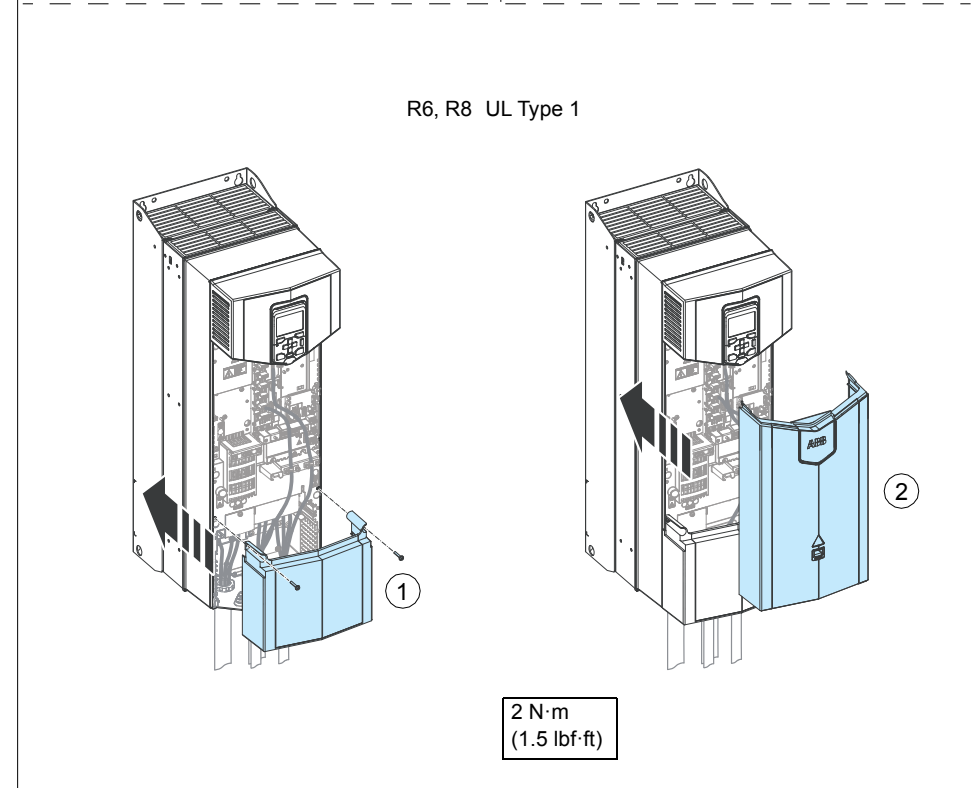
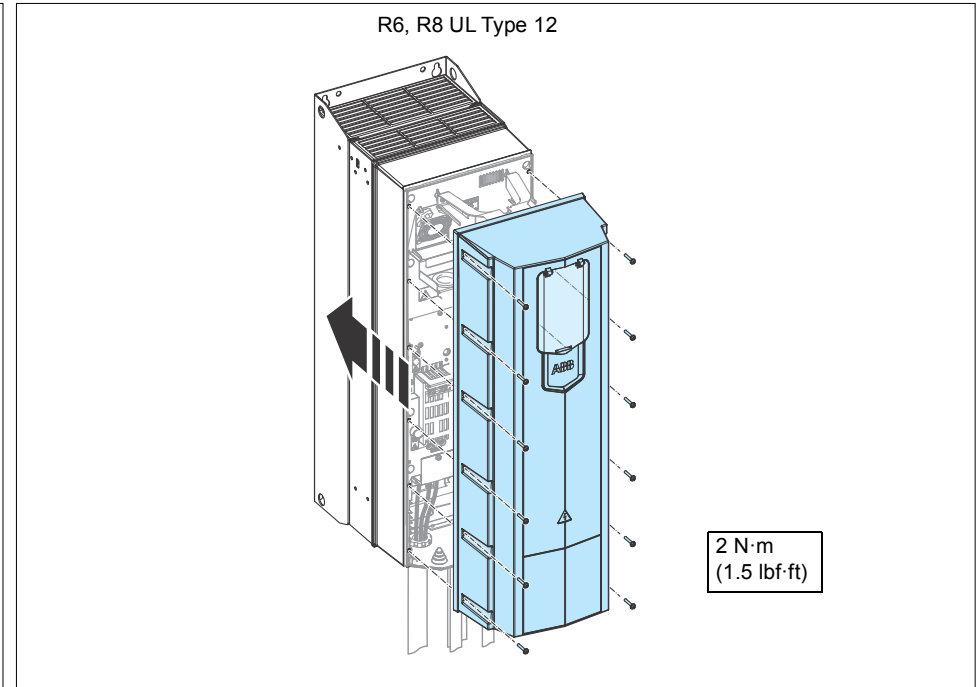

Further information

Product and service inquiries

Address any inquiries about the product to your local ABB representative, quoting the type designation and serial number of the unit in question. A listing of ABB sales, support and service contacts can be found by navigating to www.abb.com/searchchannels.

Product training

For information on ABB product training, navigate to new.abb.com/service/training.

Providing feedback on ABB Drives manuals

Your comments on our manuals are welcome. Navigate to new.abb.com/drives/manuals-feedback-form.

Document library on the Internet

You can find manuals and other product documents in PDF format on the Internet at www.abb.com/drives/documents.



abb.com/drives